

**Volume-XV**

# STRABAG

## JV of STRABAG Infrastructure & Safety Solutions GmbH and STRABAG AG

Mumbai Trans Harbour Link Project, Package-4

Design, Supply, Installation, Testing and Commissioning of Intelligent Transport System (ITS), Toll Management System, Electrical works, Highway and Bridge streetlighting system, Construction of Toll Plazas and Administrative Buildings including Command Control Centre

## Bid Documents



# INDEX

004068

S no	Particulars	Page No.
01.00	Form CHK	1
02.00	Letter of Technical Bid	4
03.00	Tender Fee (Payment Details)	7
04.00	Bid Security	9
05.00	Form ACK	14
06.00	Form ELI-1 Applicant Information Form (JV)	
	Attachments to Form ELI-1	17
06.01	Letter of Intent to enter in JV Agreement	20
07.00	Form ELI - 2: Bidder's Party Information (STRABAG Infrastructure & Safety Solutions GmbH)	23
	Attachments to Form ELI-2	
07.01	Power of Attorney	25
07.02	Incorporation Certificate / MOA & AOA / Board Resolution	32
07.03	Organizational Chart	45
07.04	List of Board of Directors	47
07.05	Share Holding Pattern	49
08.00	Form ELI - 2: Bidder's Party Information (STRABAG AG)	51
	Attachments to Form ELI-2	
08.01	Power of Attorney	53
08.02	Incorporation Certificate / MOA & AOA / Board Resolution	60
08.03	Organizational Chart	139
08.04	List of Board of Directors	141
08.05	Share Holding Pattern	143
09.00	Form ELI - 2: Bidder's Party Information (EKFON India Private Limited)	145
	Attachments to Form ELI-2	
09.01	Incorporation Certificate / MOA & AOA	147
09.02	Power of Attorney	236
	09.02.01 Board Resolution	239
09.03	Organizational Chart	241
09.04	List of Board of Directors	243
09.05	Share Holding Pattern	245
09.06	Letter of undertaking to be a specialist Subcontractor	247



# INDEX

004069

S no	Particulars	Page No.
10.00	Form ELI - 2: Bidder's Party Information (Gajra Infra Pvt Ltd.)	249
	Attachments to Form ELI-2	
10.01	Incorporation Certificate / MOA & AOA	251
10.02	Organizational Chart	258
10.03	List of Board of Directors	260
10.04	Share Holding Pattern	262
10.05	Letter of undertaking to be a specialist Subcontractor	264
11.00	Form ELI - 2: Bidder's Party Information (Ascent Engineers & Infrastructure India Pvt Ltd)	266
	Attachments to Form ELI-2	
11.01	Incorporation Certificate / MOA & AOA	268
11.02	Power of Attorney	292
11.03	Organizational Chart	297
11.04	List of Board of Directors	299
11.05	Share Holding Pattern	301
11.06	Letter of undertaking to be a specialist Subcontractor	303
12.00	Form ELI - 2: Bidder's Party Information (N.A. Construction Pvt Ltd)	305
	Attachments to Form ELI-2	
12.01	Incorporation Certificate / MOA & AOA	307
12.02	Power of Attorney	341
12.03	Organizational Chart	348
12.04	List of Board of Directors	350
12.05	Share Holding Pattern	352
12.06	Letter of undertaking to be a specialist Subcontractor	354
13.00	Form CON: Historical Contract Non-Performance (STRABAG Infrastructure & Safety Solutions GmbH)	356
14.00	Form CON: Historical Contract Non-Performance (STRABAG AG)	360
15.00	Form FIN - 1: Financial Situation (STRABAG Infrastructure & Safety Solutions GmbH)	365
	Attachments to Form FIN - 1	
15.01	Certificate from Statutory Auditor	369
15.02	Financial statements for the 5 years (2020-2016)	373
	15.02.01 Financial Statement FY - 2020	374



# INDEX

004070

S no	Particulars	Page No.
	15.02.02 Financial Statement FY - 2019	417
	15.02.03 Financial Statement FY - 2018	459
	15.02.04 Financial Statement FY - 2017	510
	15.02.05 Financial Statement FY - 2016	562
16.00	Form FIN - 1: Financial Situation (STRABAG AG)	617
	Attachments to Form FIN - 1	
16.01	Certificate from Statutory Auditor	621
16.02	Financial statements for the 5 years (2020-2016)	625
	16.02.01 Financial Statement FY - 2020	626
	16.02.02 Financial Statement FY - 2019	747
	16.02.03 Financial Statement FY - 2018	891
	16.02.04 Financial Statement FY - 2017	1038
	16.02.05 Financial Statement FY - 2016	1205
17.00	Form FIN - 2: Average Annual Turnover (STRABAG Infrastructure & Safety Solutions GmbH)	1370
	Attachments to Form FIN - 2	
17.01	Certificate from Statutory Auditor	1372
17.02	Balance Sheet & P&L for the 10 years (2020-2011)	1376
	17.02.01 Financial Statement FY - 2020	1377
	17.02.02 Financial Statement FY - 2019	1380
	17.02.03 Financial Statement FY - 2018	1383
	17.02.04 Financial Statement FY - 2017	1386
	17.02.05 Financial Statement FY - 2016	1389
	17.02.06 Financial Statement FY - 2015	1392
	17.02.07 Financial Statement FY - 2014	1395
	17.02.08 Financial Statement FY - 2013	1398
	17.02.09 Financial Statement FY - 2012	1401
	17.02.10 Financial Statement FY - 2011	1405
17.00	Form FIN - 2: Average Annual Turnover (STRABAG AG)	1431
	Attachments to Form FIN - 2	
18.01	Certificate from Statutory Auditor	1433
18.02	Balance Sheet & P&L for the 10 years (2020-2011)	1437



# INDEX

004071

S no	Particulars		Page No.
	18.02.01	Financial Statement FY - 2020	1438
	18.02.02	Financial Statement FY - 2019	1444
	18.02.03	Financial Statement FY - 2018	1450
	18.02.04	Financial Statement FY - 2017	1456
	18.02.05	Financial Statement FY - 2016	1462
	18.02.06	Financial Statement FY - 2015	1468
	18.02.07	Financial Statement FY - 2014	1474
	18.02.08	Financial Statement FY - 2013	1480
	18.02.09	Financial Statement FY - 2012	1486
	18.02.10	Financial Statement FY - 2011	1492
19.00	Form FIR - 1: Financial Resources (STRABAG Infrastructure & Safety Solutions GmbH)		1498
20.00	Form FIR - 1: Financial Resources (STRABAG AG)		1503
21.00	Form FIR - 2: Current Contract Commitments (STRABAG Infrastructure & Safety Solutions GmbH)		1508
22.00	Form FIR - 2: Current Contract Commitments (STRABAG AG)		1511
23.00	Form FIR - 2: Current Contract Commitments (EKFON India Private Limited)		1514
24.00	Form FIR - 2: Current Contract Commitments (Gajra Infra Pvt Ltd.)		1517
25.00	Form FIR - 2: Current Contract Commitments (Ascent Engineers & Infrastructure India Pvt Ltd)		1519
26.00	Form FIR - 2: Current Contract Commitments (N.A. Construction Pvt Ltd)		1521
27.00	Form EXP-4.1 General Construction Experience (STRABAG Infrastructure & Safety Solutions GmbH)		1529
28.00	Form EXP-4.1 General Construction Experience (STRABAG AG)		1534
29.00	Electrical License		1537
	29.01	Electrical License for STRABAG Infrastructure & Safety Solutions GmbH	1538
	29.02	Electrical License for STRABAG AG	1540
30.00	Form EXP - 4.2(a) Specific Construction Experience		1554
	30.01	Project - Klaus	1555
	30.02	True copy of the completion certificate	1559
	30.03	Project - Langen	1562
	30.04	True copy of the completion certificate	1566
31.00	Form EXP - 4.2(b) Specific Construction Experience in Key Activities		1569
	31.01	Key Activity No. (1)	



# INDEX

004072

S no	Particulars		Page No.
	31.01.01	Project 1 (Hyderabad ORR HTMS Project)	1571
	31.01.02	True copy of the completion certificate	1574
	31.01.03	Project 2 (NOIDA HTMS Project)	1576
	31.01.04	True copy of the completion certificate	1579
	31.01.05	Project 3 (Yamuna HTMS Project)	1581
	31.01.06	True copy of the completion certificate	1584
	31.01.07	Project 4 (Aligarh Smart City Project)	1586
	31.01.08	True copy of the completion certificate	1589
	31.01.09	Project 5 (Tumakuru Smart City Project)	1593
	31.01.10	True copy of the completion certificate	1596
	31.01.11	Project 6 (DnD Project)	1600
	31.01.12	True copy of the completion certificate	1603
31.02	Key Activity No. (2)		1605
	31.02.01	Project 1 (Hyderabad ORR TMS Project)	1607
	31.02.02	True copy of the completion certificate	1610
	31.02.03	Project 2 (GRICL Project)	1612
	31.02.04	True copy of the completion certificate	1615
	31.02.05	Project 3 (BETPL Project)	1618
	31.02.06	True copy of the completion certificate	1621
	31.02.07	Project 4 (Yamuna Express Way Project)	1624
	31.02.08	True copy of the completion certificate	1627
	31.02.09	Project 5 (PSEPL Project)	1630
	31.02.10	True copy of the completion certificate	1633
	31.02.11	Project 6 (GVK Deolikota Project)	1645
	31.02.12	True copy of the completion certificate	1648
31.03	Key Activity No. (3)		1651
	31.03.01	Project 1 (Klaus Project)	1652
	28.03.02	True copy of the completion certificate	1655
31.04	Key Activity No. (4)		1660
	31.04.01	Project 1 (Klaus Project)	1661
	31.04.02	True copy of the completion certificate	1664



# INDEX

004073

S no	Particulars		Page No.
	31.04.03	Project 2 (Langen Project)	1667
	31.04.04	True copy of the completion certificate	1670
	31.04.05	Project 3 (Oswaldiberg Project)	1673
	31.04.06	True copy of the completion certificate	1676
31.05	Key Activity No. (5)		1679
	31.05.01	STRABAG AG Project 1 (ORBI Tower, TownTown)	1681
	31.05.02	True copy of the completion certificate	1684
	31.05.03	STRABAG AG Project 2 (Pavilions Parliamentary)	1687
	31.05.04	True copy of the completion certificate	1690
	31.05.05	Subcontractor 2 - N.A. Construction Pvt Ltd Project 1 (Vasai Virar City Municipal Corporation)	1693
	31.05.06	True copy of the completion certificate	1695
	31.05.07	Subcontractor 3 - Gajra Infra Pvt Ltd. Project 1 (IL&FS Khed Sinnar Expressway)	1701
	31.05.08	True copy of the completion certificate	1704
	31.05.09	Subcontractor 3 - Gajra Infra Pvt Ltd. Project 2 (Ashoka)	1722
	31.05.10	True copy of the completion certificate	1725
	31.05.11	Subcontractor 4 - Ascent Engineers & Infrastructure India Pvt Ltd Project 1 (Gammon Tumakur - Haveri)	1731
	31.05.12	True copy of the completion certificate	1734
	31.05.13	Subcontractor 4 - Ascent Engineers & Infrastructure India Pvt Ltd Project 2 (GMR)	1736
	31.05.14	True copy of the completion certificate	1739
	31.05.15	Subcontractor 4 - Ascent Engineers & Infrastructure India Pvt Ltd Project 3 (NHAI Guabari Toll Plaza)	1741
	31.05.16	True copy of the completion certificate	1744
	31.05.17	Subcontractor 4 - Ascent Engineers & Infrastructure India Pvt Ltd Project 4 (NHAI Surjapur Toll Plaza)	1746
	31.05.18	True copy of the completion certificate	1749
32.00	Technical Proposal		1751
	32.01	Site Organization	1751
		Form PER-1	1754





# INDEX

004074

S no	Particulars		Page No.
	32.01.01	Form PER-2 - Project Manager	1758
	32.01.02	Form PER-2 - Deputy Project Manager	1763
	32.01.03	Form PER-2 - Design Manager	1770
	32.01.04	Form PER-2 - Construction Manager - Intelligent Transport System (ITS) and Toll Management System	1779
	32.01.05	Form PER-2 - Construction Manager – Electrical Works	1783
	32.01.06	Form PER-2 - Construction Manager – Civil and Buildings	1787
	32.01.07	Form PER-2 - Planning Engineer	1792
	32.01.08	Form PER-2 - Safety (Accident Prevention) Officer	1796
	32.01.09	Form PER-2 - Environment Specialist	1799
	32.01.10	Form PER-2 - Contract Specialist	1809
	32.01.11	Form PER-2 - Quality Assurance Manager	1814
	32.01.12	Form PER-2 - Administration Officer	1821
	32.02	Method Statement	1827
	32.02.01	Traffic Management System & Toll Management System Toll Management System	1828
	32.02.02	MEP System	2023
	32.03	Mobilization Schedule	2182
	32.03.01	Equipment List	2184
	32.03.02	Form EQU	2189
	32.03.03	Form MAN	2194
	32.03.04	Catalogues and Drawings	2206
	32.04	Construction Schedule	2337
	32.05	Preliminary/Bidding Design	2352
	32.06	Safety Plan / Environmental Management Plan / Health Plan	2459
	32.07	Quality Assurance Plan	2570
	32.08	Form SOG	2643
	32.09	Form SPA: Spare Parts	2645
	32.10	Form SUB	2647



# Technical Proposal

## Method Statement

### MEP System



Handwritten initials 'S/As' and a signature in blue ink.



**STRABAG**

OUTLINE METHOD STATEMENT

**एम एम आर डी ए**  
**MMRDA**

## MUMBAI TRANS HARBOUR LINK PROJECT (MTHL)

**IFB No.: MMRDA/ENG1/0002561:**

Document No.	Document Name	Document Revision
0000	<b>OUTLINE METHOD STATEMENT – INDEX</b>	R00

Sr. No.	Work Method Statement	Document No.
<b>A</b>	<b>Electrical and powering system</b>	
1	METHOD STATEMENT for Electrical Panels	0001
2	METHOD STATEMENT for Distribution Boxes	0002
3	METHOD STATEMENT for Dry type Transformer	0003
4	METHOD STATEMENT for Light Fixtures	0004
5	METHOD STATEMENT for UPS Batteries	0005
6	METHOD STATEMENT for Cable laying and termination	0006
7	METHOD STATEMENT for Cable Tray	0007
8	METHOD STATEMENT for Wiring	0008
9	METHOD STATEMENT for Conduiting	0009
10	METHOD STATEMENT for Earthing Works	0010
11	METHOD STATEMENT for Lighting Arrestor	0011
<b>B</b>	<b>METHOD STATEMENT, SCADA, and LV Systems</b>	
12	METHOD STATEMENT for BMS & SCADA	0012
13	METHOD STATEMENT for FIRE ALARM SYSTEM (FAS)	0013
14	METHOD STATEMENT for CCTV System	0014
15	METHOD STATEMENT for PUBLIC ADDRESS SYSTEM (P.A.)	0015
<b>C</b>	<b>HVAC System</b>	
16	METHOD STATEMENT for HVAC EQUIPMENTS	0016
17	METHOD STATEMENT for HVAC Ducting	0017
<b>D</b>	<b>Fire Fighting System</b>	
18	METHOD STATEMENT for FIRE FIGHTING EQUIPMENTS	0018
19	METHOD STATEMENT for FIRE FIGHTING PIPING	0019
<b>E</b>	<b>Plumbing System</b>	
20	METHOD STATEMENT for PLUMBING EQUIPMENTS	0020
21	METHOD STATEMENT for PHE PIPING	0021



**STRABAG**WORK METHOD STATEMENT –  
ELECTRICAL PANELSएम एम आर डी ए  
MMRDA**MUMBAI TRANS HARBOUR LINK PROJECT (MTHL)****IFB No.: MMRDA/ENG1/0002561:**

Document No.	Document Name		Document Revision
0001	WORK METHOD STATEMENT – ELECTRICAL PANELS		R00
	<b>Prepared By</b>	<b>Checked By</b>	<b>Approved By</b>
<b>Name</b>	Sandeep	Mubashshir	Anuj
<b>Designation</b>	Manager	DGM	GM
<b>Date</b>	29.11.2021	29.11.2021	29.11.2021



**STRABAG****WORK METHOD STATEMENT –  
ELECTRICAL PANELS****1.0 Purpose**

The purpose of generating this method statement is to define the procedure step by step to implement the correct practices for installation of HT/LT Electrical Panels.

**2.0 Scope**

This method statement refers to various work procedures contained within Strabag and Design / Drawing / Contractual specifications / Customer Quality Requirements which explains and covers the installation of HT/LT Electrical Panels.

**3.0 Reference**

- 3.1 Project Plan
- 3.2 Contract Technical Specifications
- 3.3 Approved Technical Data Sheets
- 3.4 Design Intent Drawings & Approved Shop Drawings
- 3.5 Manufacturers Catalogues & Recommendations

**4.0 Abbreviations:**

Project: MTHL  
 Client: MMRDA  
 Contractor: **STRABAG**  
 MS – Method Statement  
 FQP – Field Quality Plan  
 ICL – Installation Check List  
 CCL – Commissioning Check list  
 MHS – Material Handling System Checklist  
 MQAP – Manufacturer Quality Assurance Plan

**5.0 Responsibilities****5.1 Project Manager (Site In-charge):**

- a) Ensure all required submittals area made and required plant, tools, material manpower is available in timely manner.
- b) Ensure all execution of works area carried out according to approvals, contract specifications, and approved shop drawings, MS, FQP, ICL and CCL.
- c) Ensure necessary coordination with all involved for timely completion of job.
- d) Will attend all site review and progress review meeting time to time.
- e) Overall responsibility of the site



**STRABAG****WORK METHOD STATEMENT –  
ELECTRICAL PANELS****एम एम आर डी ए  
MMRDA****5.2 Site Engineer:**

- Timely provision of relevant and complete information, approved documents and instructions to site execution / installation team.
- Proper execution of works as per approved documents, MS, Drawings.
- The implementation of the procedures mentioned in MS with the help of concerned site engineer/ site supervisors.
- To carry out site work activities with regards to quality and safety requirements coordinating with site quality and safety representatives.

**5.3 Site Supervisor:**

- To ensure site execution works as per approved shop drawings, specifications and as per site conditions/clearance.
- Before start the work, pre-survey shall be done for the work front availability and safe working place.
- Responsible for assigned work execution at site as per time schedule.
- Coordination with site engineer for to resolve any critical issues addressed at the time of execution and during measurements.
- To monitor sub-contractor's technician, helper for work execution and issue material from stores as per requirement.
- Timely coordination with store in-charge for material availability.
- After completion of execution for assigned area, quality checks will be performed and recorded in Installation checklists. Then, same area is offered for inspection to site quality engineer.

**5.4 Site Quality Engineer:**

- Identified Site Quality Engineer is responsible for preparation of project specific quality documents in consultation and support from regional quality representative.
- Responsible for communicating with all site staff about Quality requirements and responsible for reviewing all related documents.
- Responsible for conducting Tool Box talk meeting along with Site Incharge & Site Engineers for training to site technicians staff
- Responsible for incoming material inspection & accordingly raising MIR (Material Inspection Request) for PMC/ Client inspection
- Responsible for daily site audits and recording of observation with photographs
- Responsible for installation inspection and verification of Installation checklists filled by Site supervisors
- Raising the SIR (Site Inspection Request) for PMC/ Client inspection



2021

**STRABAG****WORK METHOD STATEMENT –  
ELECTRICAL PANELS****एम एम आर डी ए  
MMRDA**

- h) Responsible for corrective actions in coordination with Project Manager & Site Engineer and close the non-conformity identified during quality audits

### 6.0 Tools/ Equipments/ Instruments used during site execution

- 6.1 Electrical & Fitter Tool box
- 6.2 Mobile Crane/Tower Crane/Farhana Crane with the capacity at least two times of the Boards load to be unloaded
- 6.3 Pipe Roller
- 6.4 Spanners / Hand tools
- 6.5 Calibrated and certified Lifting accessories e.g. chain pulley block, sling
- 6.6 Level indicator, Plumb bob
- 6.7 Crow bar
- 6.8 Screw Driver set
- 6.9 D-Shackles
- 6.10 Vacuum Pump
- 6.11 Metal free Non-woven clothes
- 6.12 Torque wrench
- 6.13 Insulation tape
- 6.14 Continuity Tester
- 6.15 Insulation Tester (Megger)
- 6.16 Pliers sets
- 6.17 Touch up paint
- 6.18 Painting brush
- 6.19 Sand paper
- 6.20 Multi-meter/Phase Sequence Meter
- 6.21 Tong Tester
- 6.22 Earthing Trolley
- 6.23 Handle to rack in rack out ACB's
- 6.24 Panel door keys
- 6.25 Rubber Mats
- 6.26 Safety / Danger sign boards

### 7.0 Installation Procedure and Methodology

#### 7.1 Preparation Work

Before the commencement of installation, the following are required to be carried out:



**STRABAG****WORK METHOD STATEMENT –  
ELECTRICAL PANELS****एम एम आर डी ए  
MMRDA**

- 7.1.1 Check that all the allocated equipment position and dimensions are correct and access toward the Electrical panel room is free from blockage.
- 7.1.2 Necessary pipe rollers/skids shall be kept ready for moving the unit.
- 7.1.3 Mobile crane or Tower crane shall be arranged along with operator.
- 7.1.4 Check work area is clean and safe.
- 7.1.5 Ensure received panels are as per approved GA, Layout/BOQ and specification.
- 7.1.6 Ensure for any damage/ short supply as per approved GA, Layout/BOQ before erection.
- 7.1.7 Verify the Name plate provided for the panels.
- 7.1.8 Ensure the control circuit terminals as per the approved drawing.
- 7.1.9 Base structure supports are fabricated & installed as per the approved GA, Layout of the panels.

**7.2 Installation Procedure for HT Panels**

- 7.2.1 Unload the units from transporting vehicle to unloading platform by using the mobile crane or tower crane or manual method with proper slings and ropes.
- 7.2.2 Place the pipe rollers or skid rollers underneath the unit and manually push it to the Electrical panel room.
- 7.2.3 Electrical panel room floor/ foundation marking shall be done prior to panel positioning.
- 7.2.4 Mount and position the panel properly on the steel base frame/ concrete plinth.
- 7.2.5 Place the foundation frame accurately on the base frame/ concrete plinth in the specified position as per approved GA drawing, Foundation layout.
- 7.2.6 Align the foundation frame with the aid of a leveling instrument.
- 7.2.7 Tolerance conditions for laying the frame to foundation
  - a. Flatness tolerance:
    - + 1mm within a measured length of 1 meter
  - b. Straightness tolerance:
    - Max. 1 mm per meter, but not greater than 2 mm on the entire frame length.
- 7.2.8 If the foundation frame consists of several parts, bolt/weld together at the prepared joints in the specified sequence, so as to obtain a flush and level top surface.
- 7.2.9 Carry out a final check on the correct position of the foundation frame and anchor it to the concrete floor with the aid of anchor fasteners/ foundation bolt.
- 7.2.10 Erect Electrical Panel (Panel with equipments and designations as shown in the





**STRABAG****WORK METHOD STATEMENT –  
ELECTRICAL PANELS**

approved GA, Layout drawing) in the specified position on the lightly greased foundation frame. Position properly the panels erected on the steel base & leveled on both axes by plumb and spirit level

- 7.2.11 If there are more than one transport section. Place second section of the Electrical panel on the lightly greased foundation frame and move it towards the section 1 with the help of rope/ chain pulley system.
- 7.2.12 Align and couple both the section of Electrical panel.
- 7.2.13 Bus bar Connection:
- The silver plated surfaces of the connections are to be cleaned with a metal free non-woven cleaning cloth and evenly greased with a thin coat of Petroleum jelly.
  - The non-silver plated surfaces of the connections are either to be brushed under grease with a wire brush, preserving the grease film or cleaned with a metal free non-woven cleaning cloth and evenly greased with a thin coat of Petroleum jelly.
- 7.2.14 Insert the bus bar components (Recommended size of nut, bolts, spring and flat washers) in the section 1 and 2 of Electrical Panels.
- 7.2.15 Tighten the fastening bolts, until the rated torque is reached as given below:

Bolt size in mm	Recommended Torque for LV bus bar in Nm
M6	5
M8	10
M10	20
M12	40
M16	90

- 7.2.16 Remove the drying agent bags, foreign bodies and tools from the busbar compartments etc. and carefully clean the compartment as necessary.
- 7.2.17 Ensure for clearances around Electrical panel as per approved GA, Layout drawing.

**7.3 Installation Procedure for LT Panels**

- 7.3.1 Unload the units from transporting vehicle to unloading platform by using the mobile crane or tower crane or manual method with proper slings and ropes.
- 7.3.2 Place the pipe rollers or skid rollers underneath the unit and manually push it to the Electrical panel room.
- 7.3.3 Electrical panel room floor/ foundation marking shall be done prior to panel positioning.



**STRABAG****WORK METHOD STATEMENT –  
ELECTRICAL PANELS**

- 7.3.4 Mount and position the panel properly on the steel base frame/ concrete plinth.
- 7.3.5 Place the foundation frame accurately on the base frame/ concrete plinth in the specified position as per approved GA drawing, Foundation layout.
- 7.3.6 Align the foundation frame with the aid of a leveling instrument.
- 7.3.7 Tolerance conditions for laying the frame to foundation
- c. Flatness tolerance:
    - + 1mm within a measured length of 1 meter
  - d. Straightness tolerance:
    - Max. 1 mm per meter, but not greater than 2 mm on the entire frame length.
- 7.3.8 If the foundation frame consists of several parts, bolt/weld together at the prepared joints in the specified sequence, so as to obtain a flush and level top surface.
- 7.3.9 Carry out a final check on the correct position of the foundation frame and anchor it to the concrete floor with the aid of anchor fasteners/ foundation bolt.
- 7.3.10 Erect Electrical Panel (Panel with equipments and designations as shown in the approved GA, Layout drawing) in the specified position on the lightly greased foundation frame. Position properly the panels erected on the steel base & leveled on both axes by plumb and spirit level
- 7.3.11 If there are more than one transport section. Place second section of the Electrical panel on the lightly greased foundation frame and move it towards the section 1 with the help of rope/ chain pulley system.
- 7.3.12 Align and couple both the section of Electrical panel.
- 7.3.13 Bus bar Connection:
- c. The silver plated surfaces of the connections are to be cleaned with a metal free non-woven cleaning cloth and evenly greased with a thin coat of Petroleum jelly.
  - d. The non-silver plated surfaces of the connections are either to be brushed under grease with a wire brush, preserving the grease film or cleaned with a metal free non-woven cleaning cloth and evenly greased with a thin coat of Petroleum jelly.
- 7.3.14 Insert the bus bar components (Recommended size of nut, bolts, spring and flat washers) in the section 1 and 2 of Electrical Panels.



7.3.15 Tighten the fastening bolts, until the rated torque is reached as given below:

Bolt size in mm	Recommended Torque for LV bus bar in Nm
M6	5
M8	10
M10	20
M12	40
M16	90

7.3.16 Remove the drying agent bags, foreign bodies and tools from the bus bar compartments etc. and carefully clean the compartment as necessary.

7.2.17 Ensure for clearances around Electrical panel as per approved GA, Layout drawing.

#### 7.4 Final Installation of HT, LT Electrical Panels

7.4.1 Clean the external surfaces of the enclosure and control cabinet on the switchgears as necessary, checking for any damage to paint work and applying touching up with a suitable paint where necessary.

7.4.2 Remove all tools and other foreign bodies from the panels.

7.4.3 Check that the general condition of the equipment is satisfactory.

7.4.4 Space clearances between the Phase, Neutral & Earth bus bar termination ends, as per approved GA, Technical Specifications

7.4.5 Check the cable entries to the panel for adequate protection against the ingress of vermin and insects.

7.4.6 Earthing connection shall be done for HT, LT Electrical panel & its accessories i.e. Breakers as per approved drawing & Technical Specifications.

7.4.7 All Medium voltage equipment's shall be earthed by two separate and distinct connections with earth, as per approved earthing layout  
(Refer following typical arrangement)

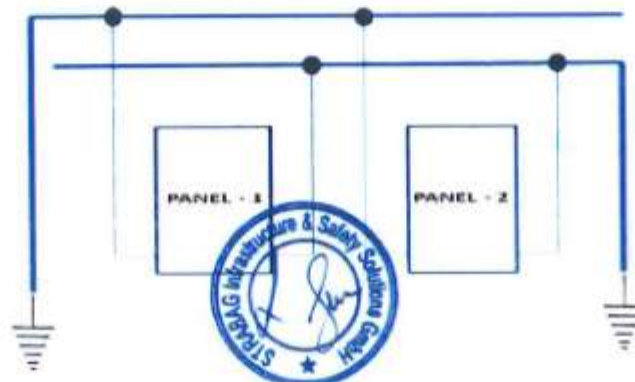

**STRABAG****WORK METHOD STATEMENT –  
ELECTRICAL PANELS**

- 7.4.8 For HT Electrical Panels – Clearance between the HT cables and Surge Arrester inside HT compartment shall be as per approved drawings.
- 7.4.9 Check for tightness of all jointing bolts, nuts, clamps and connecting terminals.
- 7.4.10 Check continuity of the bus bars & phase indication at the termination ends.
- 7.4.11 Inside panel cabinet, check for spare gland holes & other openings are sealed properly after completion of cable terminations.
- 7.4.12 Ensure cable entries to the panels for adequate protection against the ingress of vermin and insects.
- 7.4.13 Ensure Main & Feeder bus bar shall be fully insulated, and bus bar joints shall be provided with removable insulation shrouds.

**8.0 Design & Drawings**

Manufacturers Catalogues and Final approved layout drawings.

**9.0 Quality**

Procedures described in the Method Statement (MS) for Installation of HT/LT electrical panels shall be followed and use following related Quality Formats:

- Inspection Testing Plan (ITP)
- Installation Checklist (ICL)
- Commissioning Checklist (CCL)

**10.0 Distribution**

Distribution of documents shall be as per contractual Specification and agreed protocols

\*\*\*\*\*



**STRABAG**

**WORK METHOD STATEMENT –  
INSTALLATION OF  
DISTRIBUTION BOXES**

**M** एम एम आर डी ए  
**MMRDA**

**MUMBAI TRANS HARBOUR LINK PROJECT (MTHL)**

**IFB No.: MMRDA/ENG1/0002561:**

Document No.	Document Name		Document Revision
0002	<b>WORK METHOD STATEMENT - INSTALLATION OF DISTRIBUTION BOXES</b>		R00
	<b>Prepared By</b>	<b>Checked By</b>	<b>Approved By</b>
<b>Name</b>	Sandeep	Mubashshir	Anuj
<b>Designation</b>	Manager	DGM	GM
<b>Date</b>	29.11.2021	29.11.2021	29.11.2021



**STRABAG****WORK METHOD STATEMENT –  
INSTALLATION OF  
DISTRIBUTION BOXES****एम एम आर डी ए  
MMRDA****1.0 Purpose**

The purpose of generating this method statement is to define the procedure step by step to implement the correct practices for installation of Distribution box.

**2.0 Scope**

This method statement refers to various work procedures contained within Strabag and Design / Drawing / Contractual specifications / Customer Quality Requirements which explains and covers the installation of distribution boxes.

**3.0 Reference**

- 3.1 Project Plan
- 3.2 Contract Technical Specifications
- 3.3 Approved Technical Data Sheets
- 3.4 Design Intent Drawings & Approved Shop Drawings
- 3.5 Manufacturers Catalogues & Recommendations

**4.0 Abbreviations:**

Project: MTHL  
 Client: MMRDA  
 Contractor: **STRABAG**  
 MS – Method Statement  
 FQP – Field Quality Plan  
 ICL – Installation Check List  
 CCL – Commissioning Check list  
 MHS – Material Handling System Checklist  
 MQAP – Manufacturer Quality Assurance Plan

**5.0 Responsibilities****5.1 Project Manager (Site In-charge):**

- a) Ensure all required submittals area made and required plant, tools, material manpower is available in timely manner.
- b) Ensure all execution of works area carried out according to approvals, contract specifications, and approved shop drawings, MS, FQP, ICL and CCL.
- c) Ensure necessary coordination with all involved for timely completion of job.
- d) Will attend all site review and progress review meeting time to time.
- e) Overall responsibility of the site.



**STRABAG****WORK METHOD STATEMENT –  
INSTALLATION OF  
DISTRIBUTION BOXES****एम एम आर डी ए  
MMRDA****5.2 Site Engineer:**

- a) Timely provision of relevant and complete information, approved documents and instructions to site execution / installation team.
- b) Proper execution of works as per approved documents, MS, Drawings.
- c) The implementation of the procedures mentioned in MS with the help of concerned site engineer/ site supervisors.
- d) To carry out site work activities with regards to quality and safety requirements coordinating with site quality and safety representatives.

**5.3 Site Supervisor:**

- a) To ensure site execution works as per approved shop drawings, specifications and as per site conditions/clearance.
- b) Before start the work, pre-survey shall be done for the work front availability and safe working place.
- c) Responsible for assigned work execution at site as per time schedule.
- d) Coordination with site engineer for to resolve any critical issues addressed at the time of execution and during measurements.
- e) To monitor sub-contractor's technician, helper for work execution and issue material from stores as per requirement.
- f) Timely coordination with store in-charge for material availability.
- g) After completion of execution for assigned area, quality checks will be performed and recorded in Installation checklists. Then, same area is offered for inspection to site quality engineer.

**5.4 Site Quality Engineer:**

- a) Identified Site Quality Engineer is responsible for preparation of project specific quality documents in consultation and support from regional quality representative.
- b) Responsible for communicating with all site staff about Quality requirements and responsible for reviewing all related documents.
- c) Responsible for conducting Tool Box talk meeting along with Site Incharge & Site Engineers for training to site technicians staff
- d) Responsible for incoming material inspection & accordingly raising MIR (Material Inspection Request) for PMC/ Client inspection
- e) Responsible for daily site audits and recording of observation with photographs
- f) Responsible for installation inspection and verification of Installation checklists filled by Site supervisors
- g) Raising the SIR (Site Inspection Request) for PMC/ Client inspection
- h) Responsible for corrective actions in combination with Project Manager & Site Engineer and close the non-conformity identified during quality audits





**WORK METHOD STATEMENT –  
INSTALLATION OF  
DISTRIBUTION BOXES**



## 6.0 Tools and Tackles

- 6.1 Electricians Tool Box
- 6.2 Fitters Tool Box
- 6.3 Spanners / Hand tools
- 6.4 Hack saw
- 6.5 Level indicator, Plumb bob
- 6.6 Screw driver set
- 6.7 Plier set
- 6.8 Wire cutter
- 6.9 Wire Insulation remover
- 6.10 Screw driver set
- 6.11 Hand drill machine
- 6.12 Drill bits set
- 6.13 Insulation tape

## 7.0 INSTALLATION PROCEDURE AND METHDOLOGY

### 7.1 Before Installation

- 7.1.1 Ensure work area is ready and safe to start the installation of Distribution Boxes.
- 7.1.2 Refer to approved drawings related to the area of installation and ensure that required materials are available as per approved material submittals.
- 7.1.3 Ensure that all civil and finishing works are completed for the area of installation and area released / cleared by civil agency to proceed with further work of shifting, positioning of Distribution box installations.
- 7.1.4 Ensure the floor surface is ready for installation of base frames wherever envisaged.

### 7.2 Installation Procedure

- 7.2.1 Installation works shall be carried out only with respect to approved drawings of latest revision.
- 7.2.2 All Distribution boxes shall be kept clear of gas and water pipes.
- 7.2.3 Installation shall be carried out in accordance with manufacturers' recommendations.





**STRABAG****WORK METHOD STATEMENT –  
INSTALLATION OF  
DISTRIBUTION BOXES****एम एम आर डी ए  
MMRDA**

applicable standards and project specifications to ensure compliance with requirements.

- 7.2.4 Base frames shall be fixed with Z section and grouted wherever with anchor fastener.
- 7.2.5 Distribution boxes shall be installed serially and with level verticality as per manufacturer's recommendations and site lay out, Hight of 1.2mtr. from ground level.
- 7.2.6 Proper alignment and orientation of Distribution boxes shall be maintained.
- 7.2.7 Termination shall be confirmed with approved drawing.
- 7.2.8 The details of each Distribution boxes shall be checked before installation as per Approved drawings & location mentioned in drawing.
- 7.2.9 Wirings shall be done and properly identified with ferrules according to approved drawings, specifications.
- 7.2.10 All spare cable entries and other openings shall be closed with watertight sealant/ rubber grommets

**8.0 Design & Drawings**

Manufacturers Catalogues and Final approved layout drawings.

**9.0 Quality**

Procedures described in the Method Statement (MS) for Installation of distribution box shall be followed and use following related Quality Formats:

- Inspection Testing Plan (ITP)
- Installation Checklist (ICL)
- Commissioning Checklist (CCL)

**10.0 Distribution**

Distribution of documents shall be as per contractual Specification and agreed protocols

\*\*\*\*\*



**STRABAG**

WORK METHOD STATEMENT –  
INSTALLATION OF DRY-TYPE  
TRANSFORMER



## MUMBAI TRANS HARBOUR LINK PROJECT (MTHL)

**IFB No.: MMRDA/ENG1/0002561:**

Document No.	Document Name		Document Revision
0003	WORK METHOD STATEMENT - INSTALLATION OF DRY-TYPE TRANSFORMER		R00
	<b>Prepared By</b>	<b>Checked By</b>	<b>Approved By</b>
<b>Name</b>	Sandeep	Mubashshir	Anuj
<b>Designation</b>	Manager	DGM	GM
<b>Date</b>	29.11.2021	29.11.2021	29.11.2021





**WORK METHOD STATEMENT –  
INSTALLATION OF DRY-TYPE  
TRANSFORMER**



### 1.0 Purpose

The purpose of generating this method statement is to define the procedure step by step to implement the correct practices for installation of DRY-TYPE TRANSFORMER.

### 2.0 Scope

This method statement refers to various work procedures contained within Strabag and Design / Drawing / Contractual specifications / Customer Quality Requirements which explains and covers the installation of DRY-TYPE TRANSFORMER.

### 3.0 Reference

- 3.1 Project Plan
- 3.2 Contract Technical Specifications
- 3.3 Approved Technical Data Sheets
- 3.4 Design Intent Drawings & Approved Shop Drawings
- 3.5 Manufacturers Catalogues & Recommendations
- 3.6 Code of practices for installation of Transformers (BIS Code & IE Rules)

### 4.0 Abbreviations:

Project: MTHL  
Client: MMRDA  
Contractor: **STRABAG**  
MS – Method Statement  
FQP – Field Quality Plan  
ICL – Installation Check List  
CCL – Commissioning Check list  
MHS – Material Handling System Checklist  
MQAP – Manufacturer Quality Assurance Plan

### 5.0 Responsibilities

#### 5.1 Project Manager (Site In-charge):

- a) Ensure all required submittals area made and required plant, tools, material manpower is available in timely manner.
- b) Ensure all execution of works area carried out according to approvals, contract specifications, and approved shop drawings, MS, FQP, ICL and CCL.
- c) Ensure necessary coordination with all involved for timely completion of job.
- d) Will attend all site review and progress review meeting time to time.
- e) Overall responsibility of the site.





**WORK METHOD STATEMENT –  
INSTALLATION OF DRY-TYPE  
TRANSFORMER**



**5.2 Site Engineer:**

- Timely provision of relevant and complete information, approved documents and instructions to site execution / installation team.
- Proper execution of works as per approved documents, MS, Drawings.
- The implementation of the procedures mentioned in MS with the help of concerned site engineer/ site supervisors.
- To carry out site work activities with regards to quality and safety requirements coordinating with site quality and safety representatives.

**5.3 Site Supervisor:**

- To ensure site execution works as per approved shop drawings, specifications and as per site conditions/clearance.
- Before start the work, pre-survey shall be done for the work front availability and safe working place.
- Responsible for assigned work execution at site as per time schedule.
- Coordination with site engineer for to resolve any critical issues addressed at the time of execution and during measurements.
- To monitor sub-contractor's technician, helper for work execution and issue material from stores as per requirement.
- Timely coordination with store in-charge for material availability.
- After completion of execution for assigned area, quality checks will be performed and recorded in Installation checklists. Then, same area is offered for inspection to site quality engineer.

**5.4 Site Quality Engineer:**

- Identified Site Quality Engineer is responsible for preparation of project specific quality documents in consultation and support from regional quality representative.
- Responsible for communicating with all site staff about Quality requirements and responsible for reviewing all related documents.
- Responsible for conducting Tool Box talk meeting along with Site Incharge & Site Engineers for training to site technicians staff
- Responsible for incoming material inspection & accordingly raising MIR (Material Inspection Request) for PMC/ Client inspection
- Responsible for daily site audits and recording of observation with photographs
- Responsible for installation inspection and verification of Installation checklists filled





**WORK METHOD STATEMENT –  
INSTALLATION OF DRY-TYPE  
TRANSFORMER**



by Site supervisors

- g) Raising the SIR (Site Inspection Request) for PMC/ Client inspection
- h) Responsible for corrective actions in coordination with Project Manager & Site Engineer and close the non-conformity identified during quality audits.

### 6.0 Tools & Plants

Tools & Plants required for this activity as per listed below.

- 6.1 Mobile Crane/Tower Crane with the capacity at least two times of the transformer Load to be unloaded.
- 6.2 Pipe Roller
- 6.3 Spanners / Hand tools
- 6.4 Calibrated and certified Lifting accessories e.g. chain pulley block, sling
- 6.5 Jacks
- 6.6 D-Shackles
- 6.7 Level indicator.
- 6.8 Plumb Bob.
- 6.9 Crow bar.
- 6.10 Screw Driver set.
- 6.11 Continuity Tester.
- 6.12 Hammers.
- 6.13 Metal-Free Non-Woven Cleaning Clothes
- 6.14 Wire Brush.
- 6.15 Petroleum Jelly.
- 6.16 Torque Wrench
- 6.17 Insulation Tapes.
- 6.18 Vacuum Pump
- 6.19 Touch up Paint.
- 6.20 Painting Brush.
- 6.30 Electrical & Fitter tool box
- 6.31 Megger
- 6.32 HV Test Kit
- 6.33 Multi-meter
- 6.34 Blower
- 6.35 Primary Injection Kit





**WORK METHOD STATEMENT –  
INSTALLATION OF DRY-TYPE  
TRANSFORMER**



636 Tong Tester

637 Hardwares

## 7.0 Installation Procedure and Methodology

### 7.1 Preparation Work

Before the commencement of installation, the following are required to be carried out

- i. Lifting / handling shall be done with only tested slings and crane (qualified operator) as per sling mark if provided on the Transformer Tank.
- ii. When lifting a transformer by the lugs and shackles provided for the purpose care shall be taken that simultaneous use should be made of all lugs/shackles in order to avoid any unbalance while lifting.
- iii. Care shall be taken such that the lifting chains/sling should not interfere, get pressurized or rub harshly with any part of transformer to avoid damage.
- iv. It will be ensured that all cover bolts are tightened fully before lifting complete transformer.
- v. In case where it is necessary to use lifting jacks or travelling jacks, jacking pads shall be used.
- vi. For transporting transformer from storage place to work site, transformer shall be taken on a suitable capacity truck/trailer, properly lashed/tied with steel/manila ropes and with stoppers to avoid damage due to sliding or tilting due to jerks / vibrations.
- vii. If not immediately placed on plinth, care shall be taken so that the transformers shall be kept on wooden sleepers slightly raised from ground to avoid damage due to water.
- viii. Stoppers shall be used at the wheels to avoid sliding/rolling.
- ix. Transformer Tag No. / Sr. No. as per the name plate details shall be identified for its designated location as per layout drawings.
- x. Area Classification like hazardous or non-hazardous shall be ascertained before installation.
- xi. For transformer ratings which are received pre-assembled care shall be taken to check for any damages to Enclosure, Marshalling box, Cable Chambers, Canopy, doors, Covers etc.

### 7.2 Installation Procedure

- i. Installation of transformer is carried out in accordance with Manufacturer Manual, requirement of applicable standards, best installation practices and project specific compliances.
- ii. The name plate shall be checked against equipment data sheet to confirm conformity with approved drawings/documents.
- iii. The transformer shall be placed in the leveled foundation / rail / channels and positioned in such a way that the corner lines/ coordinates with reference to bus duct connected to switchgear (wherever applicable).





**WORK METHOD STATEMENT –  
INSTALLATION OF DRY-TYPE  
TRANSFORMER**



- iv. Wheel stoppers shall be placed and clamped on to the transformer immediately to prevent any movement or sliding
- v. For short distance HT cable length (i.e. 200ft or less) between Transformer and HT Panel/ HT Circuit Breaker, then surge arrestors must be provided on Transformer HT side

### 7.3 Locking the Wheels

- i. When installing a transformer with wheels, there is always a danger that gusts of wind, unevenness of the surface, short-circuit shocks or earth movements may cause the transformer to start moving
- ii. Lock two (or better still all four) of the wheels using steel brackets of suitable size.



**Typical locking device for flanged wheels**

- iii. If the transformer is mounted on the foundation without wheels, fix it at the points where the wheels are removed. Check with manufacturer to see whether design is suitable for such a mounting method.
- iv. Locking devices which are bolted to the rails can only be used with concrete-recessed rails if tapped holes are provided on the rail.
- v. A different type of locking device is generally used when the distance between the wheels is not too great as shown in below figures.
- vi. The same device can be used for plain wheels



**STRABAG**

**WORK METHOD STATEMENT –  
INSTALLATION OF DRY-TYPE  
TRANSFORMER**

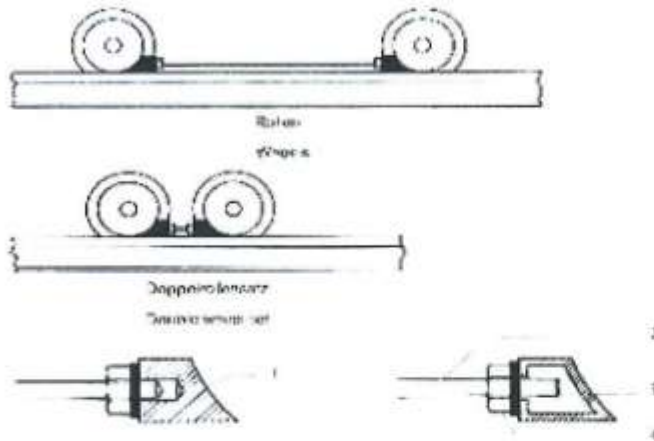
**एम एम आर डी ए  
MMRDA**

1. Hardwood Stop Block (Indoor)
2. Threaded Steel Rod
3. Stop Block (Steel)
4. Locknut

- vii. Marshalling Box, Cable Box shall be mounted as per GA drawings and cable terminations done.
- viii. In case of on load tap changing transformers, the OLTC driving mechanism shall be mounted as per the manufacturer's instruction manual.
- ix. When cable Boxes are provided they shall be mounted and cable terminations done.
- x. In case single core cables installed -
- Aluminum (Non-ferrous material) gland plate to be used
  - Single core cable armour earthing to be done at only one end of gland terminations
- xi. Tighten fastening bolts, until the rated torque is reached as given below:

Bolt size in mm	Recommended Torque For HV/ LV bus bar in Nm
M6	5
M8	10
M10	20
M12	40
M16	90

- xii. Proper cable termination or bus duct connections at LV side and at HV side shall be carried out.
- xiii. Proper control cable termination, control panel heater cable termination, power supply cable termination shall be ensured.
- xiv. Danger/Caution boards (MV or HV) shall be installed.







**WORK METHOD STATEMENT –  
INSTALLATION OF DRY-TYPE  
TRANSFORMER**



- xv. Insert the end joint bus bar components (Recommended size of nut, bolts, spring and flat washers).
- xvi. The neutral Bushing connection shall be done as per approved drawing and Technical Specification.
- xvii. After completion of all HT/LT/Neutral cable connections recheck all joint for tightness.
- xviii. Suitable paint touch up shall be done by bush painting
- xix. Earthing of the transformer shall be carried out as per the drawings and in accordance with IS 3043 -1966 (Code of practice for Earthing).

#### 7.4 Final Installation of Transformer

- i. Clean the external surfaces of the enclosures and control cabinet on the transformer as necessary, checking for any damage to paintwork and touching up with a suitable paint where necessary.
- ii. Remove all tools and other foreign bodies from the enclosure of the transformer.
- iii. Check that the general condition of the transformer is satisfactory.
- iv. Check the cable / Bus duct entries to the transformer for adequate protection against the ingress of vermin and insects.
- v. Complete the installation checklist
- vi. When installation is complete paint finishes which are damaged shall be touched upon. Bare spots shall be primed before applying finish paint.

#### 7.4 Touch up Painting at Site

- i. Any damage to the painting of the transformer and accessories shall be made good after erection work is completed.
- ii. If a welding has been done on the transformer at site, the paint film burnt by the welding shall be removed by wire brush or metal spatula.
- iii. Remove the rust by wire brush and emery paper #80/#100.





**WORK METHOD STATEMENT –  
INSTALLATION OF DRY-TYPE  
TRANSFORMER**



- iv. Wash away the oil, grease, dirt and dust by using suitable solvent and dry it up.
- v. Polish the surface to be painted by using emery paper #80/#100 and then clean the surface.
- vi. After cleaning, stir the ready mixed rust resistant primer paint "red oxide". Before applying the paint, confirm the correct viscosity.
- vii. Apply the paint uniformly by using a brush.
- viii. Drying time for the paint is normally 4 hours.
- ix. After the first coat of paint is dried up, mix and stir the finish coat paint to the desired viscosity and apply by brush uniformly. Drying time of finish coat paint is normally 6hrs.
- x. Inspect the repainted surface and do re-painting if the painting is not uniform and un-painted surface is visible.
- xi. Recommended viscosities for painting:
  - For brushing : 50~55 sec
  - For Spraying: 20~25 sec
  - Pressure for spraying: 55~60 psi
  - Time gap between two coating: 24 hours
  - Total dry film thickness after final coating: 80~100 micron.

**DO'S and DON'TS FOR SAFETY MEASURES / PRECAUTIONS**

Safety measures / precautions should be given top most priority during inspection / erection works. Any mishap during the process will result in delay in erection, endangering human life, endangering equipment life etc.

**DO'S**

- Make sure that nothing is kept inside the pockets before one enters inside the main unit. Also take off the wrist watches and shoes.
- List up all the tools and materials to be taken inside and check it after coming out to make sure that no tools are left inside.
- There must be a protective guard for lamp to be taken inside
- Keep inspection covers open for supply of fresh air when working inside.
- When one person is working inside, second person must be outside for emergency.
- Use rings spanners and tie them to the wrist of the person or somewhere outside the tank





**WORK METHOD STATEMENT –  
INSTALLATION OF DRY-TYPE  
TRANSFORMER**



- Be careful during connections where bolted joints are involved so that nut, washers, etc. are not dropped inside the tank
- If it is very necessary to weld some lugs or brackets etc. these should be welded to tank stiffeners taking all precautions to avoid fire hazards.
- De-energize the unit by circuit breakers and line switches while working on energized units.
- Attach the caution tags "DO NOT OPERATE THE SWITCHES" while working on units which are energized.
- Make sure firefighting equipment is available at the oil treatment equipment as well as work place and adjacent to transformer.
- Transformer enclosure, control cabinets etc. as well as treatment equipment shall be connected with permanent earthing system of the station.
- Check and thoroughly investigate the transformer whenever an alarm or protective device is operated
- If inspection covers are removed or any gasket joint is to be tightened, then tighten the bolts evenly to avoid uneven pressure.
- Check and clean the relay and alarm contacts. Check also their operation and accuracy and if required change the setting.
- Check protection circuits periodically
- Check WTI connections for healthiness.
- Check door seal of the marshalling box. Change the rubber lining if require.
- Do jacking only at jacking pad

**DON'TS**

- Do not take any fibrous material such as cotton waste inside while repairing.
- Do not drop any tools / material inside
- Do not stand on leads / cleats
- Do not weld, braze or solder inside the enclosure
- Do not weld anything to the enclosure from outside
- Do not smoke near the transformer.
- Do not energize the transformer without investigation of the transformer whenever any alarm of protection has operated.
- Do not re-energize the transformer without conducting all Pre-commissioning checks. The results must be compared with factory test results
- Do not use low capacity lifting jacks / slings on transformer for jacking/sliding
- Do not overload the transformer beyond standard limit
- Do not change WTI alarm and trip frequently. Setting should done as per manufacturers instruction
- Do not leave any connection loose
- Do not meddle with protection circuit
- Do not leave marshalling box doors open they must be locked
- Do not switch off the heater in marshalling box except to be periodically cleaned





**WORK METHOD STATEMENT –  
INSTALLATION OF DRY-TYPE  
TRANSFORMER**



- Do not allow unauthorized entry near transformer
- Do not store transformer for long period after reaching site. It must be erected and commissioned at the earliest.
- Do not parallel transformers which do not fulfill the conditions required for paralleling.
- Do not overload the transformer beyond limit specified in IS 6600
- Do not leave secondary terminal of any CT open

#### 8.0 Design & Drawings

Manufacturers Catalogues and Final approved layout drawings.

#### 9.0 Quality

Procedures described in the Method Statement (MS) for Installation of Dry type transformer shall be followed and use following related Quality Formats;

- Inspection Testing Plan (ITP)
- Installation Checklist (ICL)
- Commissioning Checklist (CCL)

#### 10.0 Distribution

Distribution of documents shall be as per contractual Specification and agreed protocols

\*\*\*\*\*



**STRABAG****WORK METHOD STATEMENT -  
INSTALLATION OF LIGHT  
FIXTURES****एम एम आर डी ए  
MMRDA****MUMBAI TRANS HARBOUR LINK PROJECT (MTHL)****IFB No.: MMRDA/ENG1/0002561:**

Document No.	Document Name		Document Revision
0004	<b>WORK METHOD STATEMENT - INSTALLATION OF LIGHT FIXTURES</b>		R00
	<b>Prepared By</b>	<b>Checked By</b>	<b>Approved By</b>
<b>Name</b>	Sandeep	Mubashshir	Anuj
<b>Designation</b>	Manager	DGM	GM
<b>Date</b>	29.11.2021	29.11.2021	29.11.2021





**WORK METHOD STATEMENT -  
INSTALLATION OF LIGHT  
FIXTURES**



### 1.0 Purpose

The purpose of generating this method statement is to define the procedure step by step to implement the correct practices for installation of LIGHT FIXTURES.

### 2.0 Scope

This method statement refers to various work procedures contained within Strabag and Design / Drawing / Contractual specifications / Customer Quality Requirements which explains and covers the installation of LIGHT FIXTURES.

### 3.0 Reference

- 3.1 Project Plan
- 3.2 Contract Technical Specifications
- 3.3 Approved Technical Data Sheets
- 3.4 Design Intent Drawings & Approved Shop Drawings
- 3.5 Manufacturers Catalogues & Recommendations

### 4.0 Abbreviations:

Project: MTHL  
 Client: MMRDA  
 Contractor: **STRABAG**  
 MS – Method Statement  
 FQP – Field Quality Plan  
 ICL – Installation Check List  
 CCL – Commissioning Check list  
 MHS – Material Handling System Checklist  
 MQAP – Manufacturer Quality Assurance Plan

### 5.0 Responsibilities

#### 5.1 Project Manager (Site In-charge):

- a) Ensure all required submittals area made and required plant, tools, material manpower is available in timely manner.
- b) Ensure all execution of works area carried out according to approvals, contract specifications, and approved shop drawings, MS, FQP, ICL and CCL.
- c) Ensure necessary coordination with all involved for timely completion of job.
- d) Will attend all site review and progress review meeting time to time.
- e) Overall responsibility of the site.

#### 5.2 Site Engineer:





**WORK METHOD STATEMENT -  
INSTALLATION OF LIGHT  
FIXTURES**



- a) Timely provision of relevant and complete information, approved documents and instructions to site execution / installation team.
- b) Proper execution of works as per approved documents, MS, Drawings.
- c) The implementation of the procedures mentioned in MS with the help of concerned site engineer/ site supervisors.
- d) To carry out site work activities with regards to quality and safety requirements coordinating with site quality and safety representatives.

**5.3 Site Supervisor:**

- a) To ensure site execution works as per approved shop drawings, specifications and as per site conditions/clearance.
- b) Before start the work, pre-survey shall be done for the work front availability and safe working place.
- c) Responsible for assigned work execution at site as per time schedule.
- d) Coordination with site engineer for to resolve any critical issues addressed at the time of execution and during measurements.
- e) To monitor sub-contractor's technician, helper for work execution and issue material from stores as per requirement.
- f) Timely coordination with store in-charge for material availability.
- g) After completion of execution for assigned area, quality checks will be performed and recorded in Installation checklists. Then, same area is offered for inspection to site quality engineer.

**5.4 Site Quality Engineer:**

- a) Identified Site Quality Engineer is responsible for preparation of project specific quality documents in consultation and support from regional quality representative.
- b) Responsible for communicating with all site staff about Quality requirements and responsible for reviewing all related documents.
- c) Responsible for conducting Tool Box talk meeting along with Site Incharge & Site Engineers for training to site technicians staff
- d) Responsible for incoming material inspection & accordingly raising MIR (Material Inspection Request) for PMC/ Client inspection
- e) Responsible for daily site audits and recording of observation with photographs
- f) Responsible for installation inspection and verification of Installation checklists filled by Site supervisors
- g) Raising the SIR (Site Inspection Request) for PMC/ Client inspection
- h) Responsible for corrective actions in combination with Project Manager & Site Engineer and close the non-conformity identified during quality audits



**STRABAG****WORK METHOD STATEMENT -  
INSTALLATION OF LIGHT  
FIXTURES** **एम एम आर डी ए  
MMRDA****6.0 Tools and Tackles**

- 6.1 Electricians Tool Box
- 6.2 Fitters Tool Box
- 6.3 Spanners / Hand tools
- 6.4 Hack saw
- 6.5 Level indicator, Plumb bob
- 6.6 Screw driver set
- 6.7 Crimping machine
- 6.8 Plier set
- 6.9 Wire cutter
- 6.10 Wire Insulation remover
- 6.11 Screw driver set
- 6.12 Hand drill machine
- 6.13 Drill bits set
- 6.14 Insulation tape
- 6.15 LUX Meter

**7.0 INSTALLATION PROCEDURE AND METHODOLOGY****7.1 Before Installation**

- 7.1.1 All external wrapping and packing materials should be removed and discarded. Care should be taken when removing the light fixtures from packing.
- 7.1.2 Check sufficient storage area is available.
- 7.1.3 Site Engineer shall ensure that all wiring is completed, tested and site is cleared from civil section to install light fittings. All cement works & coloring of the wall is completed and cleared of installation of wiring accessories.
- 7.1.4 Prior to start the installation, site engineer shall ensure that approved drawings related to the installation area are referred to and required materials are available at site as per approved drawings / material submittal documents.
- 7.1.5 Site Engineer shall ensure that all lighting fixtures are received at site as per approved material submittal and as per client/consultant approval.

**7.2 Pre-Installation Checks**

- 7.2.1 Installation works shall be carried out only with respect to approved drawings of later







**WORK METHOD STATEMENT -  
INSTALLATION OF LIGHT  
FIXTURES**



revision.

- 7.2.2 Lighting fixture in false ceiling area shall be coordinated with the architect and the Civil engineer for the symmetrical and aesthetic layout of the fittings, A/C diffuser, fire alarm detector etc.
- 7.2.3 The details of each lighting fixture shall be check before installation as per approved drawings & location mentioned in drawing
- 7.2.4 Wiring shall be completed before starting of work.
- 7.2.5 All lighting fixture shall be kept clear of gas and water pipes.
- 7.2.6 Before fixing lamps, all light fixtures shall be cleaned.
- 7.2.7 Correct type of lamps shall be available, as per approved drawing/ material submittal documents.

**7.3 Installation of Light Fixtures on Ceiling/ Wall**

- 7.3.1 Identify the location of light fixtures and mark the same on Ceiling/ Wall surface.
- 7.3.2 Drill the holes on the Ceiling/ Wall to fix the fixtures.
- 7.3.3 Lighting fixtures which are heavy shall be supported from the ceiling usinggalvanized caddy clip and heavy gauge GI rod.
- 7.3.4 Lighting fixtures fixed in service areas shall be fixed using anchor bolts, metal expansion anchor rods/chain & Using PG Gland for cable entries.
- 7.3.5 Insert the wires inside light fixtures and fix the fixtures to the Ceiling, Wall.
- 7.3.6 Proper alignment and orientation of light fixture shall be maintained.
- 7.3.7 Termination & control point of lighting fixture shall be confirmed as per approved drawing.
- 7.3.8 Connect the wires to the terminal of Light fixtures.
- 7.3.9 The continuity of the wires shall be checked by continuity tester.
- 7.3.10 Wirings shall be installed and properly labeled/ identify with ferrules per approved drawings.
- 7.3.11 Fix the lamp inside the fixture & fix the cover.



**STRABAG****WORK METHOD STATEMENT -  
INSTALLATION OF LIGHT  
FIXTURES****M** एम एम आर डी ए  
**MMRDA****7.4 Installation of Light Fixtures Below False Ceiling**

- 7.4.1 Identify the location of light fixture and mark same on the false ceiling sheets, as per approved drawings.
- 7.4.2 Fixing of lighting fixtures above ducts, pipes, trays and trunking shall be avoided.
- 7.4.3 Provide the opening in the false ceiling sheet suitable for light fixture fixing.
- 7.4.4 Drill the hole in the ceiling and provide 'J' hook to suspend the chain.
- 7.4.5 Suspend the chain/ gripple wire to the required length, as per approved installation drawing.
- 7.4.6 Hang the light fixture to the suspended chain and adjust the height in such a way the bottom of light fixture is aligned with bottom surface of false ceiling sheet.
- 7.4.7 Connect the wires to the terminal of Light fixture.
- 7.4.8 The continuity of the wires shall be checked by continuity tester.
- 7.4.9 Wirings shall be installed and properly labeled/ identify with ferrules per approved drawings.
- 7.4.10 Fix the lamp inside the fixture & fix the cover.

**8.0 Design & Drawings**

Manufacturers Catalogues and Final approved layout drawings.

**9.0 Quality**

Procedures described in the Method Statement (MS) for Installation of light fixtures shall be followed and use following related Quality Formats:

- Inspection Testing Plan (ITP)
- Installation Checklist (ICL)
- Commissioning Checklist (CCL)

**10.0 Distribution**

Distribution of documents shall be as per contractual Specification and agreed protocols

\*\*\*\*\*



**STRABAG**

WORK METHOD STATEMENT –  
 INSTTALATION OF BATTERIES  
 for UPS/ BATTERY CHARGER



### MUMBAI TRANS HARBOUR LINK PROJECT (MTHL)

**IFB No.: MMRDA/ENG1/0002561:**

Document No.	Document Name		Document Revision
0005	WORK METHOD STATEMENT - INSTTALATION OF INSTTALATION OF BATTERIES for UPS/ BATTERY CHARGER		R00
	<b>Prepared By</b>	<b>Checked By</b>	<b>Approved By</b>
<b>Name</b>	Sandeep	Mubashshir	Anuj
<b>Designation</b>	Manager	DGM	GM
<b>Date</b>	29.11.2021	29.11.2021	29.11.2021





**WORK METHOD STATEMENT –  
INSTALLATION OF BATTERIES  
for UPS/ BATTERY CHARGER**



### 1.0 Purpose

The purpose of generating this method statement is to define the procedure step by step to implement the correct practices for installation of BATTERIES for UPS/ BATTERY CHARGER.

### 2.0 Scope

This method statement refers to various work procedures contained within Strabag and Design / Drawing / Contractual specifications / Customer Quality Requirements which explains and covers the installation of BATTERIES for UPS/ BATTERY CHARGER.

### 3.0 Reference

- 3.1 Project Plan
- 3.2 Contract Technical Specifications
- 3.3 Approved Technical Data Sheets
- 3.4 Design Intent Drawings & Approved Shop Drawings
- 3.5 Manufacturers Catalogues & Recommendations

### 4.0 Abbreviations:

Project: MTHL  
Client: MMRDA  
Contractor: **STRABAG**  
MS – Method Statement  
FQP – Field Quality Plan  
ICL – Installation Check List  
CCL – Commissioning Check list  
MHS – Material Handling System Checklist  
MQAP – Manufacturer Quality Assurance Plan

### 5.0 Responsibilities

#### 5.1 Project Manager (Site In-charge):

- a) Ensure all required submittals area made and required plant, tools, material manpower is available in timely manner.
- b) Ensure all execution of works area carried out according to approvals, contract specifications, and approved shop drawings, MS, FQP, ICL and CCL.
- c) Ensure necessary coordination with all involved for timely completion of job.
- d) Will attend all site review and progress review meeting time to time.
- e) Overall responsibility of the site.





**WORK METHOD STATEMENT –  
INSTALLATION OF BATTERIES  
for UPS/ BATTERY CHARGER**



**5.2 Site Engineer:**

- Timely provision of relevant and complete information, approved documents and instructions to site execution / installation team.
- Proper execution of works as per approved documents, MS, Drawings.
- The implementation of the procedures mentioned in MS with the help of concerned site engineer/ site supervisors.
- To carry out site work activities with regards to quality and safety requirements coordinating with site quality and safety representatives.

**5.3 Site Supervisor:**

- To ensure site execution works as per approved shop drawings, specifications and as per site conditions/clearance.
- Before start the work, pre-survey shall be done for the work front availability and safe working place.
- Responsible for assigned work execution at site as per time schedule.
- Coordination with site engineer for to resolve any critical issues addressed at the time of execution and during measurements.
- To monitor sub-contractor's technician, helper for work execution and issue material from stores as per requirement.
- Timely coordination with store in-charge for material availability.
- After completion of execution for assigned area, quality checks will be performed and recorded in Installation checklists. Then, same area is offered for inspection to site quality engineer.

**5.4 Site Quality Engineer:**

- Identified Site Quality Engineer is responsible for preparation of project specific quality documents in consultation and support from regional quality representative.
- Responsible for communicating with all site staff about Quality requirements and responsible for reviewing all related documents.
- Responsible for conducting Tool Box talk meeting along with Site Incharge & Site Engineers for training to site technicians staff
- Responsible for incoming material inspection & accordingly raising MIR (Material Inspection Request) for PMC/ Client inspection
- Responsible for daily site audits and recording of observation with photographs
- Responsible for installation inspection and verification of Installation checklists filled by Site supervisors





**WORK METHOD STATEMENT –  
INSTALLATION OF BATTERIES  
for UPS/ BATTERY CHARGER**



- g) Raising the SIR (Site Inspection Request) for PMC/ Client inspection
- h) Responsible for corrective actions in coordination with Project Manager & Site Engineer and close the non-conformity identified during quality audits

**6.0 Tools/ Equipments/ Instruments used during site execution**

- 6.1 Electrical & Fitter Tool box
- 6.2 Spanners all sizes / Hand tools
- 6.3 Screw Driver set
- 6.4 Metal free Non-woven clothes
- 6.5 Torque wrench
- 6.6 Insulation tape
- 6.7 Pliers sets
- 6.8 AC / DC Multi-meter
- 6.9 Tong Tester
- 6.10 Safety / Danger sign boards

**7.0 Installation Procedure and Methodology**

**7.1 Preparation Work**

Before the commencement of installation, the following are required to be carried out:

- 7.1.1 Check the route from stores to installation location is free for easy movement of the equipment
- 7.1.2 Check that all the allocated equipment position and dimensions are correct and the access toward the Battery Room is free from blockage
- 7.1.3 Check the base frame on which the Battery Rack panel is to be mounted is properly fixed and aligned as per approved drawing / specification.
- 7.1.4 Checkout and ensure the tools & tackles required are sufficient at site.
- 7.1.5 Unpack the Batteries and ensure that the debris / packing materials are disposed from site to prescribed location
- 7.1.6 Ensure no damages during unpacking of Batteries
- 7.1.7 Lifting / handling shall be done with only tested slings
- 7.1.8 Battery Type, Tag Nos/ Sr. Nos. as per the name plate details shall be identified for its designated location as per general arrangement drawings.
- 7.1.9 The name plate shall be checked with approved data sheet / General arrangement





**WORK METHOD STATEMENT –  
INSTALLATION OF BATTERIES  
for UPS/ BATTERY CHARGER**



drawing.

7.1.10 Availability of all relevant documents i.e. – Approved drawings, Factory test report, check list, etc.

## 7.2 Installation of Battery

7.2.1 The racks for mounting the batteries shall be installed as per the layout drawing.

7.2.2 The batteries shall be placed in racks in the battery room as per layout drawing

7.2.3 The batteries shall be interconnected as per drawing / scheme.

7.2.4 7.2.4 Testing and commissioning will be done as per Manufacturer Manual.

7.2.5 7.2.5 Ensure the protection of Battery & Battery Charger panel till commissioning

## 8.0 Design & Drawings

Manufacturers Catalogues and Final approved layout drawings.

## 9.0 Quality

Procedures described in the Method Statement (MS) for Installation of batteries shall be followed and use following related Quality Formats;

- Inspection Testing Plan (ITP)
- Installation Checklist (ICL)
- Commissioning Checklist (CCL)

## 10.0 Distribution

Distribution of documents shall be as per contractual Specification and agreed protocols

\*\*\*\*\*



**STRABAG**WORK METHOD STATEMENT - CABLE  
LAYING AND TERMINATION एम एम आर डी ए  
MMRDA**MUMBAI TRANS HARBOUR LINK PROJECT (MTHL)****IFB No.: MMRDA/ENG1/0002561:**

Document No.	Document Name		Document Revision
0006	WORK METHOD STATEMENT - CABLE LAYING AND TERMINATION		R00
	<b>Prepared By</b>	<b>Checked By</b>	<b>Approved By</b>
<b>Name</b>	Sandeep	Mubashshir	Anuj
<b>Designation</b>	Manager	DGM	GM
<b>Date</b>	29.11.2021	29.11.2021	29.11.2021







WORK METHOD STATEMENT - CABLE  
LAYING AND TERMINATION



### 1.0 Purpose

The purpose of generating this method statement is to define the procedure step by step to implement the correct practices for cable laying and termination.

### 2.0 Scope

This method statement refers to various work procedures contained within Strabag and Design / Drawing / Contractual specifications / Customer Quality Requirements which explains and covers the installation of cable laying and termination.

### 3.0 Reference

- 3.1 Project Plan
- 3.2 Contract Technical Specifications
- 3.3 Approved Technical Data Sheets
- 3.4 Design Intent Drawings & Approved Shop Drawings
- 3.5 Manufacturers Catalogues & Recommendations

### 4.0 Abbreviations:

Project: MTHL  
Client: MMRDA  
Contractor: **STRABAG**  
MS – Method Statement  
FQP – Field Quality Plan  
ICL – Installation Check List  
CCL – Commissioning Check list  
MHS – Material Handling System Checklist  
MQAP – Manufacturer Quality Assurance Plan

### 5.0 Responsibilities

#### 5.1 Project Manager (Site In-charge):

- a) Ensure all required submittals area made and required plant, tools, material manpower is available in timely manner.
- b) Ensure all execution of works area carried out according to approvals, contract specifications, and approved shop drawings, MS, FQP, ICL and CCL.
- c) Ensure necessary coordination with all involved for timely completion of job.
- d) Will attend all site review and progress review meeting time to time.
- e) Overall responsibility of the site.



**STRABAG**WORK METHOD STATEMENT - CABLE  
LAYING AND TERMINATION

**एम एम आर डी ए**  
**MMRDA**
**5.2 Site Engineer:**

- Timely provision of relevant and complete information, approved documents and instructions to site execution / installation team.
- Proper execution of works as per approved documents, MS, Drawings.
- The implementation of the procedures mentioned in MS with the help of concerned site engineer/ site supervisors.
- To carry out site work activities with regards to quality and safety requirements coordinating with site quality and safety representatives.

**5.3 Site Supervisor:**

- To ensure site execution works as per approved shop drawings, specifications and as per site conditions/clearance.
- Before start the work, pre-survey shall be done for the work front availability and safe working place.
- Responsible for assigned work execution at site as per time schedule.
- Coordination with site engineer for to resolve any critical issues addressed at the time of execution and during measurements.
- To monitor sub-contractor's technician, helper for work execution and issue material from stores as per requirement.
- Timely coordination with store in-charge for material availability.
- After completion of execution for assigned area, quality checks will be performed and recorded in Installation checklists. Then, same area is offered for inspection to site quality engineer.

**5.4 Site Quality Engineer:**

- Identified Site Quality Engineer is responsible for preparation of project specific quality documents in consultation and support from regional quality representative.
- Responsible for communicating with all site staff about Quality requirements and responsible for reviewing all related documents.
- Responsible for conducting Tool Box talk meeting along with Site Incharge & Site Engineers for training to site technicians staff
- Responsible for incoming material inspection & accordingly raising MIR (Material Inspection Request) for PMC/ Client inspection
- Responsible for daily site audits and recording of observation with photographs
- Responsible for installation inspection and verification of Installation checklists filled by Site supervisors
- Raising the SIR (Site Inspection Request) for PMC/ Client inspection
- Responsible for corrective actions in coordination with Project Manager & Site Engineer and close the non-conformity identified during quality audits



**STRABAG**WORK METHOD STATEMENT - CABLE  
LAYING AND TERMINATIONएम एम आर डी ए  
MMRDA**6.0 Tools & Equipment's**

Tools and equipment required for this activity as per listed below:

- 6.1 Mobile Crane/Tower Crane with the capacity at least two times of the cable drum shall be used for unloading.
- 6.2 Cable drums lifting jack and shaft as per requirements
- 6.3 Spanners / Hand tools
- 6.4 Lifting accessories e.g. chain pulley block, sling
- 6.5 Cable rollers.
- 6.6 Crowbar.
- 6.7 Insulation Resistance tester (Megger).
- 6.8 High Voltage kit with probes.
- 6.9 Hot Gun.
- 6.10 HT cable termination kits
- 6.11 Screw driver sets.
- 6.12 Metal free-Non-woven cloths.
- 6.13 Cable Cutter / Insulation remover.
- 6.14 Plier sets.
- 6.15 Continuity tester.
- 6.16 Multimeter.

**7.0 Installation Procedure and Methodology****7.1 Preparation Work**

Before the commencement of laying the cables, the following to be carried out:

- 7.1.1 Check that all the allocated cable routes are ready with the cable trenches/trays and they are free from blockage.
- 7.1.2 Necessary cable rollers/skids or crowbar shall be kept ready for smooth laying.



- 7.1.3 Mobile crane or Tower crane shall be arranged along with qualified operator.



**STRABAG**WORK METHOD STATEMENT - CABLE  
LAYING AND TERMINATIONएम एम आर डी ए  
MMRDA

7.1.4 Check work area is clean and safe.

7.1.5 Prior to installation, refer to the approved drawings related to the area of installation and ensure that required materials are available at site.

7.1.6 Cable drum should be visually inspected for damage, which may have occurred during transport.



7.1.7 Manufacturer's seal on the inner and outer cable ends should be examined.

7.1.8 Ensure the received cables make, size, voltage grade, conductor, insulation type (XLPE/PVC) as per drawing & specification.

7.1.9 Identification of the cores.

7.1.10 Cable route / trench as per the drawing layout.

7.1.11 Depth & width of the cable trench

7.1.12 Cutting schedule should be prepared based on the cable schedule

7.1.13 Ensure barriers shall be erected to prevent vehicles inadvertently falling into the excavation

7.1.14 Check the cable drums for any physical damage. Also check that the cable end seals are proper and in position



**STRABAG**WORK METHOD STATEMENT - CABLE  
LAYING AND TERMINATIONएम एम आर डी ए  
MMRDA**7.2 Transportation and Handling of Cables**

7.2.1 Roll the drum only in the direction of painted arrow on the drum flanges and only for the short distances.

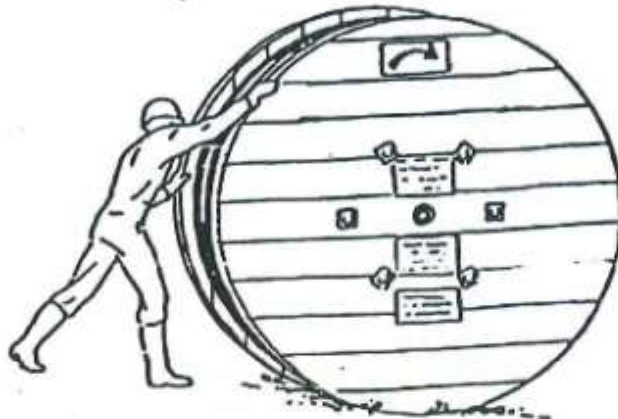

**Drum must be rolled in the direction of the arrow**

7.2.2 Use pair of jacks and shaft for mounting cable drum before laying.

7.2.3 The cable should always be pulled off from the top of the drum. While doing so, drum should be placed in such a way that painted arrow points to the opposite direction of pulling.

7.2.4 Cable drum breaking provision shall be made, in order during sudden stop and further rolling & consequent bucking of cables.

7.2.5 The drum is jacked up to such a height that plank needed for breaking cannot jam. Heavy drums should be jacked up with hydraulic drum pedestals.

7.2.6 Cable drum stopper shall be used while laying the cables from the drum, in order to avoid further rolling of cable drums.



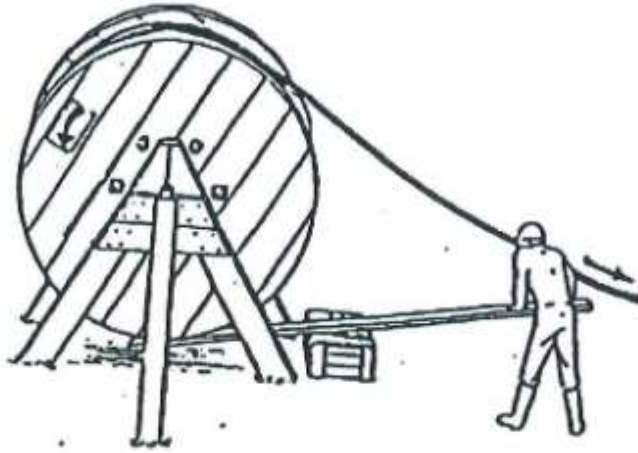

**Braking of drum. The arrow is for direction of rolling of drum on ground and not for the pulling**

- 7.2.7 With Temperature below 3°C, the cables shall be warmed before laying out, otherwise bending can damage the insulation/protective covering of cables.
- 7.2.8 Warming of cables may be achieved by storing the cable drum for adequately longer period, not less than 24 hours, in a heated building or in a tent with hot air heaters.
- 7.2.9 Size and length of the cables to be checked before cutting.
- 7.2.10 Conduct Insulation Resistance test with Hand driven/Battery operated/AC power operated Megger/ Insulation Tester on the cable before laying and record the result. All new cables should be tested for insulation resistance before jointing.

**Voltage Grade of cable****Voltage Rating of IR Tester**

1.1kV	500V
3.3 kV	1000V
6.6 kV	1000V
11 kV	5000 V
22 kV	5000V



7.2.11 The voltage rating of insulation tester for cables of different voltage grades should be chosen from the following table as per IS 1255:

### 7.3 Cable laying on Cable trays

- 7.3.1 For laying cables in trays, the trays shall be curved enough at right angles to allow the cable with correct bending radius.
- 7.3.2 Adequate cable trays shall be provided 10 percentage extra gap or as per approved drawing/ layout, considering the number of cables.
- 7.3.3 Laying will be carried out as per approved drawing and segregation of Power, Control and Signal cables shall be maintained as per drawing.
- 7.3.4 Bending radius of LT cables will not be less than 12 times the overall diameter of the cable while that of HT cables shall not be less than 15 times the overall diameter of the cable.
- 7.3.5 Emergency or Non-emergency power cable to be on separate tray as per approved drawing.

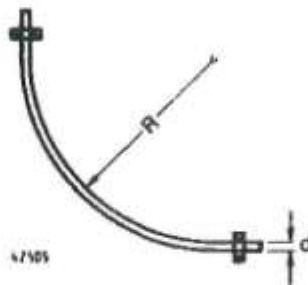

Cables	Plastic-Insulated cables PVC
$V \leq 0.6/1kV$ $V > 0.6/1kV$	$R = 12 \times d$ $R = 15 \times d$
Single-core cables	$R = 15 \times d$ **

\*\* For cables  $V > 18/30kV = 25 \times d$  or see manufacturers instruction.

- 7.3.6 Cable shall be tagged using 2mm thick aluminum strip (defining cable no., size & from-to) at predetermined interval as per drawing. The tag will be tied to the cable using GI 20SWG wire/ cable tie/ nylon rope (or as mentioned in specifications)
- 7.3.7 Cables shall be dressed properly.
- 7.3.8 Cable should be cleaned all wet area and dirt mud / dust.
- 7.3.9 Cables shall be secured to vertical cable tray using cleats and ties for horizontal cable tray.
- 7.3.10 Overlapping shall be avoided in trays, If the cable is crossing, Should be in right angle.

**STRABAG**WORK METHOD STATEMENT - CABLE  
LAYING AND TERMINATIONएम एम आर डी ए  
MMRDA

7.3.11 Earth conductor shall be laid in parallel with cables.

7.3.12 On completion of laying and dressing continuity and insulation resistance checks shall be conducted and record shall be maintained.

7.3.13 Cable Ends shall be providing double compression gland.

7.3.14 All conductors requiring bolted connections shall be terminated with compression lugs using compression crimping tools.



Narrow marks for hand pliers

7.3.15 Cable lugs shall be tinned copper compression heavy duty type or aluminum lugs as specified.



1-Terminal 70 sq.mm, 3-Stud hole diameter, 4-conductor cross-section, 5-manufacturers mark, 6-Die code

7.3.16 Terminations shall be carried out as per Lug manufacturer installation guidelines/ procedures.

#### Crimping Sequence

In order to avoid bulging, the first crimp of a terminal should not be at the open end of the socket but at the nearest point to the stud hole, unless stated otherwise in the instructions applicable to the termination.



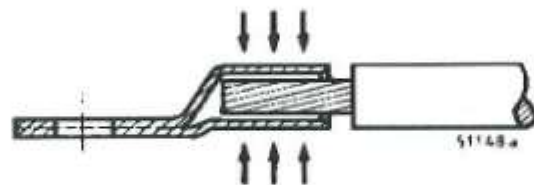
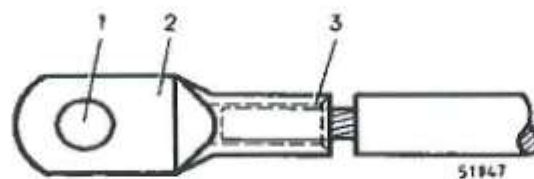
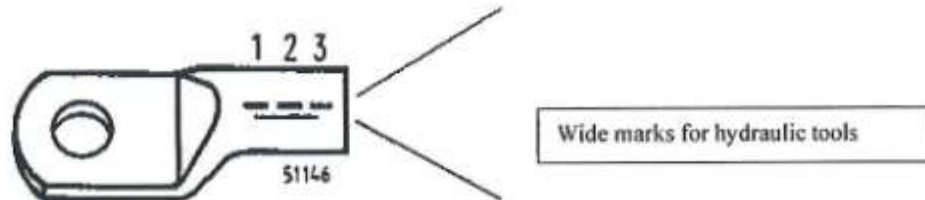

**STRABAG**WORK METHOD STATEMENT - CABLE  
LAYING AND TERMINATIONएम एम आर डी ए  
MMRDA

Crimping

1- Stud hole 2- Palm 3- Socket

In case of connecting sleeves the two ends of the cables must be inserted to the center and in order to avoid bulging, crimping should start at the center and proceed outwards.

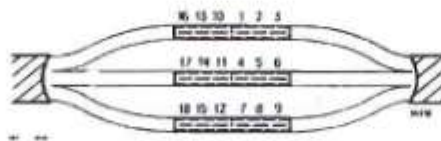
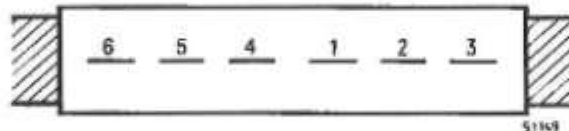

#### Crimping sequence on a connecting sleeve for single-core cable & three-core cable

7.3.17 HV cable earthing shall be done through to termination kit.

7.3.18 Termination of all LT cables shall be done using brass cable glands with copper lugs of proper size and bi-metallic plates will be used.

7.3.19 Opening of cable glands will be done by using required diameter knock-out punches so as to avoid deformation of gland plate.

7.3.20 The cable route markers shall be erected at every 30mtr & at least 150mm above ground level in way that accumulation of dust & water is avoided. Joint Marker shall be provided



every cable jointing point as per drawing / specifications.

- 7.3.21 The spacing between the cables should be maintained as specified in approved drawing.
- 7.3.22 The HDPE / RCC Hume pipes for crossing roads, water, oil, gas & sewage points shall be provided as per drawing.
- 7.3.23 Cable laying at Road crossing shall be laid as per technical specifications.
- 7.3.24 Mechanical protection for underground cable as per approved drawing and specification.
- 7.3.25 The cables to be bend as per IS 1255 & route markers shall be provided at both ends.
- 7.3.26 For multiple runs of cables, separation between individual cables shall be maintained as per approved drawing.
- 7.3.27 Cables shall be run on walls, structure or laid on cable trays, as required. Only approved type of cable support or fixing such as cleats, saddles, hangers or straps shall be used.
- 7.3.28 Cables shall be secured to cable trays by means of single fixing type of saddles or cable ties.

#### 7.4 HT Cable Termination

- 7.4.1 HT cables shall be terminated to HT panels by using approved make of HT cable termination kit only. (kit make : Raychem, straight heat shrinkable joint )
- 7.4.2 HT termination shall be done by experienced licensed cable jointer only.
- 7.4.3 Continuity & Insulation resistance shall be checked before starting the termination work.
- 7.4.4 Conductor resistance shall be measured in comparison with factory test results
- 7.4.5 P.I. Value shall be measured
- 7.4.6 Each core shall be HV tested individually by applying 30KV DC by gradually increasing and keep for 5 minutes and take the reading of leakage current at start and end of test. Increase trend of leakage current is not desirable. IR checks shall be done with 5 KV DC motorized megger after the test to check the healthiness of cable.
- 7.4.7 Check the cable entries to the panel for adequate protection against the ingress of vermin and insects.
- 7.4.8 Before commencement of termination both the ends of the cable shall be identified by continuity check with Multimeter / Cable tester to confirm the phase sequence and Insulation resistance shall be measured with 5KV calibrated motorized Megger.
- 7.4.9 After preparation of end termination and crimping of lugs with crimping tool of required size, measure insulation resistance value with 5KV calibrated motorized megger and if found satisfactory in comparison with factory test results, HV test shall be conducted with HI POT kit.



**STRABAG**WORK METHOD STATEMENT - CABLE  
LAYING AND TERMINATIONएम एम आर डी ए  
MMRDA

7.4.10 Crimping of lugs with cable conductor shall be done by use of crimping machine only After completion of work HV withstand test shall be conducted & IR value shall be checked before & after HV test.

7.4.11 Remove all tools and other foreign to the bodies from the cable chamber of the panels.

## 7.5 L.T. Cable termination

7.5.1 LT termination shall be done by experienced /skilled person only

7.5.2 Continuity & Insulation resistance shall be checked before starting the termination work

7.5.3 Crimping of lugs with cable's conductor shall be done by use of hydraulic crimping machine only.

7.5.4 Remove all tools and other foreign bodies from the cable chamber of the panels.

7.5.5 Check the cable entries to the panels for adequate protection against the ingress of vermin and insects.

7.5.6 Before commencement of termination both the ends of the cable shall be identified by continuity check with Multi-meter / Continuity tester.

7.5.7 After preparation of end termination and crimping of lugs with crimping tool of required size, measure insulation resistance value with 1/0.5 KV calibrated manual/motorized megger and if found satisfactory with earlier result then connection to be done in the panel.

7.5.8 Provide support proper support at 300 mm from gland termination to avoid stress of gland.

## 7.6 Notes on Single Core Cables

7.6.1 When cables run for several kilometers long, cables are transposed at one-third and two- third of overall length (Transposing of single core cables over long run)

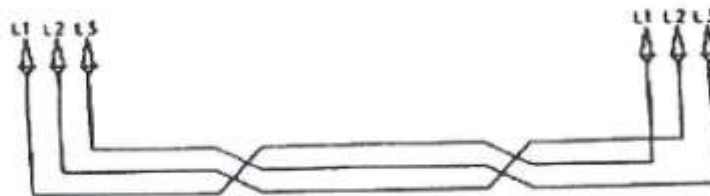

7.6.2 Single core cables must be laid in one plane in parallel arrangement, in trefoil or bundle arrangement

7.6.3 For above arrangements cables must be fixed with non-magnetic taps or clips

7.6.4 For several parallel single core cables, use following arrangement:

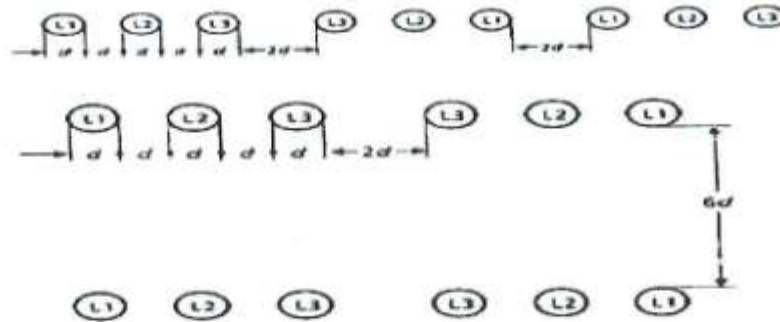

**STRABAG**
**WORK METHOD STATEMENT - CABLE  
LAYING AND TERMINATION**

**एम एम आर डी ए  
MMRDA**

Where,  $d$  = cable outer sheath diameter

Clearance between the individual systems in one plane should equal  $2 \times d$ , In case systems laid one above the other it should equal  $6 \times d$

- 7.6.5 Grouping of single core cables above 1kV and in one plane should be avoided because increase in sheath losses and number of racks/tray require.
- 7.6.6 Laying of single core cables in trefoil or bundle arrangement for optimizing condition with respect to current distribution and sheath losses, use following arrangement:

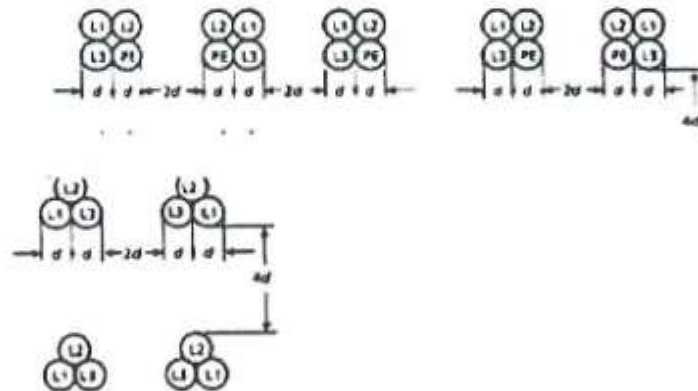

Where,  $d$  = cable outer sheath diameter

Clearance between the individual systems in one plane should equal bundle diameter, In case systems laid one above the other it should equal  $4 \times d$

- 7.6.7 Single core cables must not be bundled when laid in earth, but they must be bundled or secured when they have entered building as given by engineering department / drawings



**STRABAG**WORK METHOD STATEMENT - CABLE  
LAYING AND TERMINATION

**एम एम आर डी ए**  
MMRDA
**8.0 Design & Drawings**

Manufacturers Catalogues and Final approved layout drawings.

**9.0 Quality**

Procedures described in the Method Statement (MS) for cable laying and termination works shall be followed and use following related Quality Formats;

- Inspection Testing Plan (ITP)
- Installation Checklist (ICL)
- Commissioning Checklist (CCL)

**10.0 Distribution**

Distribution of documents shall be as per contractual Specification and agreed protocols

\*\*\*\*\*



**STRABAG**WORK METHOD STATEMENT –  
CABLE TRAY**MUMBAI TRANS HARBOUR LINK PROJECT (MTHL)****IFB No.: MMRDA/ENG1/0002561:**

Document No.	Document Name		Document Revision
0007	WORK METHOD STATEMENT – CABLE TRY		R00
	<b>Prepared By</b>	<b>Checked By</b>	<b>Approved By</b>
<b>Name</b>	Sandeep	Mubashshir	Anuj
<b>Designation</b>	Manager	DGM	GM
<b>Date</b>	29.11.2021	29.11.2021	29.11.2021



**STRABAG****WORK METHOD STATEMENT –  
CABLE TRAY****एम एम आर डी ए  
MMRDA****1.0 Purpose**

The purpose of generating this method statement is to define the procedure step by step to implement the correct practices for installation of Cable Trays.

**2.0 Scope**

This method statement refers to various work procedures contained within Strabag and Design / Drawing / Contractual specifications / Customer Quality Requirements which explains and covers the installation of Cable Trays.

**3.0 Reference**

- 3.1 Project Plan
- 3.2 Contract Technical Specifications
- 3.3 Approved Technical Data Sheets
- 3.4 Design Intent Drawings & Approved Shop Drawings
- 3.5 Manufacturers Catalogues & Recommendations

**4.0 Abbreviations:**

Project: MTHL  
 Client: MMRDA  
 Contractor: **STRABAG**  
 MS – Method Statement  
 FQP – Field Quality Plan  
 ICL – Installation Check List  
 CCL – Commissioning Check list  
 MHS – Material Handling System Checklist  
 MQAP – Manufacturer Quality Assurance Plan

**5.0 Responsibilities****5.1 Project Manager (Site In-charge):**

- a) Ensure all required submittals area made and required plant, tools, material manpower is available in timely manner.
- b) Ensure all execution of works area carried out according to approvals, contract specifications, and approved shop drawings, MS, FQP, ICL and CCL.
- c) Ensure necessary coordination with all involved for timely completion of job.
- d) Will attend all site review and progress review meeting time to time.
- e) Overall responsibility of the site.



**STRABAG****WORK METHOD STATEMENT –  
CABLE TRAY****एम एम आर डी ए  
MMRDA****5.2 Site Engineer:**

- a) Timely provision of relevant and complete information, approved documents and instructions to site execution / installation team.
- b) Proper execution of works as per approved documents, MS, Drawings.
- c) The implementation of the procedures mentioned in MS with the help of concerned site engineer/ site supervisors.
- d) To carry out site work activities with regards to quality and safety requirements coordinating with site quality and safety representatives.

**5.3 Site Supervisor:**

- a) To ensure site execution works as per approved shop drawings, specifications and as per site conditions/clearance.
- b) Before start the work, pre-survey shall be done for the work front availability and safe working place.
- c) Responsible for assigned work execution at site as per time schedule.
- d) Coordination with site engineer for to resolve any critical issues addressed at the time of execution and during measurements.
- e) To monitor sub-contractor's technician, helper for work execution and issue material from stores as per requirement.
- f) Timely coordination with store in-charge for material availability.
- g) After completion of execution for assigned area, quality checks will be performed and recorded in Installation checklists. Then, same area is offered for inspection to site quality engineer.

**5.4 Site Quality Engineer:**

- a) Identified Site Quality Engineer is responsible for preparation of project specific quality documents in consultation and support from regional quality representative.
- b) Responsible for communicating with all site staff about Quality requirements and responsible for reviewing all related documents.
- c) Responsible for conducting Tool Box talk meeting along with Site Incharge & Site Engineers for training to site technicians staff
- d) Responsible for incoming material inspection & accordingly raising MIR (Material Inspection Request) for PMC/ Client inspection
- e) Responsible for daily site audits and recording of observation with photographs
- f) Responsible for installation inspection and verification of Installation checklists filled by Site supervisors
- g) Raising the SIR (Site Inspection Request) for PMC/ Client inspection
- h) Responsible for corrective actions in coordination with Project Manager & Site Engineer and close the non-conformity identified during quality audits





**STRABAG****WORK METHOD STATEMENT –  
CABLE TRAY****एम एम आर डी ए  
MMRDA****6.0 Tools & Equipment's**

Tools and equipment required for this activity as per listed below:

- 6.1. Hand Drilling machines
- 6.2. Spanners / Hand tools
- 6.3. Water Level and Plumb
- 6.4. Fitter tools
- 6.5. Drill bits sets
- 6.6. Metal-Free Non-Woven Cleaning Cloths
- 6.7. Screw Driver sets
- 6.8. Hack saw & blades

**7.0 Installation Procedure and Methodology****7.1 Preparation Work**

Before the commencement of installation of the cables trays, the following are required to be carried out:

- 7.1.1 For unloading of cable tray at site using forklift or by hand unloading following correct method to be followed

**CORRECT****NOT CORRECT****CORRECT****NOT CORRECT**

- 7.1.2 Check that all the allocated cable routes are ready with the supports and free from blockage.



- 7.1.3 Check work area is clean and safe.
- 7.1.4 Before fabrication each and every angle length will be straightened if fabrication at site is foreseen.
- 7.1.5 If fabrications of trays are foreseen at site, all necessary supports and tray shall be fabricated as per the approved drawings.

## 7.2 Installation Procedure

- 7.2.1 Erection of fabricated / prefabricated trays and supports at site locations shall be done as per layout drawings using necessary platforms, tower ladders, scaffolding and other safety measures.
- 7.2.2 Check the cable trays for any physical damage if pre-fabricated.
- 7.2.3 Check the support provided for the cable trays installation with the following minimum requirements
- Support fixing interval shall be 1.2 MTR. Or as per Approved drawings.
  - Support size and material that will be as per Approved drawing and specification.
  - Support shall be painted before Installation two coat of primer and two coats of finish paint.
  - Distance between two tiers shall be minimum of 250 to 400 mm. Or as per site condition.
  - Separate cable tray shall be provided for HT, LT and Control cables.
- 7.2.4 Cable trays shall be placed on supports & clamped with the supports. 1.2 MTR. Or as per approval drawing. As a general practice, avoid placing splice plates over supports or at mid-span. Refer following figure

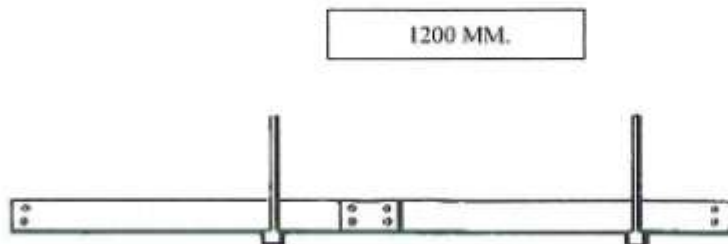

- 7.2.5 All cable trays shall be bonded together by means of coupling plates/ splice plates.
- 7.2.6 Splice plate/ Coupling Plate shall be placed on outside of cable tray, unless otherwise specified by manufacturer, with the bolts head on the inside of cable tray.

Refer following figure



**STRABAG****WORK METHOD STATEMENT –  
CABLE TRAY****एम एम आर डी ए  
MMRDA**

7.2.7 Cable tray bends shall be used readymade/ factory-made.

7.2.8 Recommended support locations for Cable tray and fittings shall be as follows:

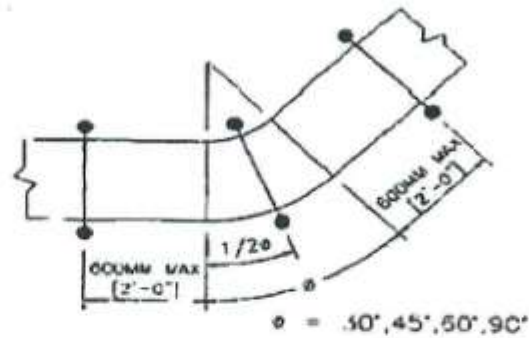
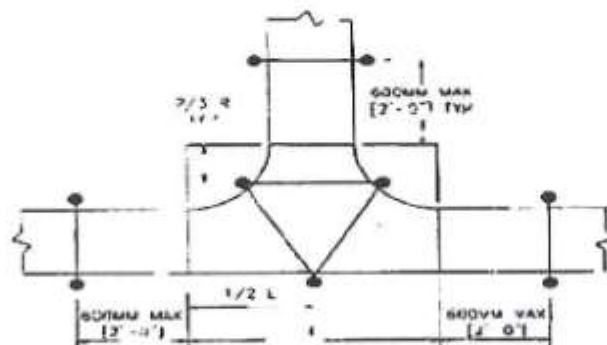
**I. Horizontal ELBOW Support**CENTER SUPPORT NOT REQUIRED  
ON 12" RADIUS 30° & 45° FITTINGS**II. Horizontal TEE Support**

CENTER SUPPORT NOT REQUIRED ON 12" RADIUS FITTINGS

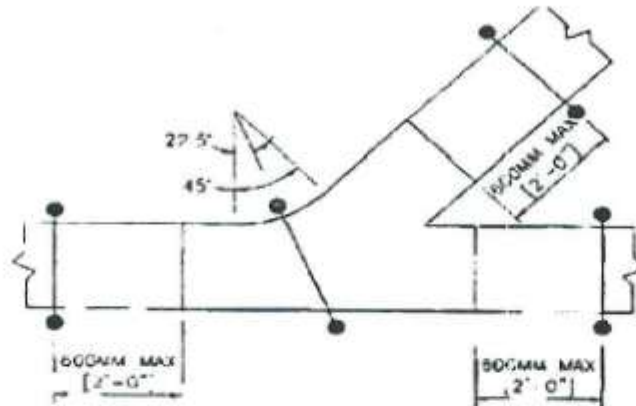
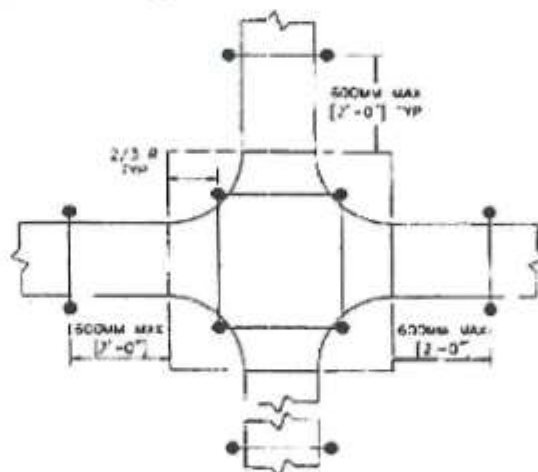

**STRABAG****WORK METHOD STATEMENT –  
CABLE TRAY****एम एम आर डी ए  
MMRDA****III. Horizontal WYE Support**CENTER SUPPORT NOT REQUIRED  
ON 12" RADIUS FITTINGS**III. Horizontal CROSS Support**

CENTER SUPPORT NOT REQUIRED ON 12" RADIUS FITTINGS

7.2.9 All trays and supports are aligned properly with water level and supports are anchored with fasteners.

7.2.10 Fixing Hardware's will be fabricated at site or readymade factory items.



**STRABAG****WORK METHOD STATEMENT –  
CABLE TRAY****एम एम आर डी ए  
MMRDA****8.0 Design & Drawings**

Manufacturers Catalogues and Final approved layout drawings.

**9.0 Quality**

Procedures described in the Method Statement (MS) for Installation of cable trays shall be followed and use following related Quality Formats:

- Inspection Testing Plan (ITP)
- Installation Checklist (ICL)
- Commissioning Checklist (CCL)

**10.0 Distribution**

Distribution of documents shall be as per contractual Specification and agreed protocols

\*\*\*\*\*



**STRABAG****WORK METHOD STATEMENT -  
WIRING****MUMBAI TRANS HARBOUR LINK PROJECT (MTHL)****IFB No.: MMRDA/ENG1/0002561:**

Document No.	Document Name		Document Revision
0008	<b>WORK METHOD STATEMENT - WIRING</b>		R00
	<b>Prepared By</b>	<b>Checked By</b>	<b>Approved By</b>
<b>Name</b>	Sandeep	Mubashshir	Anuj
<b>Designation</b>	Manager	DGM	GM
<b>Date</b>	29.11.2021	29.11.2021	29.11.2021



**STRABAG****WORK METHOD STATEMENT -  
WIRING****1.0 Purpose**

The purpose of generating this method statement is to define the procedure step by step to implement the correct practices for installation of Point wiring.

**2.0 Scope**

This method statement refers to various work procedures contained within Strabag and Design / Drawing / Contractual specifications / Customer Quality Requirements which explains and covers the installation of Point wiring.

**3.0 Reference**

- 3.1 Project Plan
- 3.2 Contract Technical Specifications
- 3.3 Approved Technical Data Sheets
- 3.4 Design Intent Drawings & Approved Shop Drawings
- 3.5 Manufacturers Catalogues & Recommendations

**4.0 Abbreviations:**

Project: MTHL  
 Client: MMRDA  
 Contractor: **STRABAG**  
 MS – Method Statement  
 FQP – Field Quality Plan  
 ICL – Installation Check List  
 CCL – Commissioning Check list  
 MHS – Material Handling System Checklist  
 MQAP – Manufacturer Quality Assurance Plan

**5.0 Responsibilities****5.1 Project Manager (Site In-charge):**

- a) Ensure all required submittals area made and required plant, tools, material manpower is available in timely manner.
- b) Ensure all execution of works area carried out according to approvals, contract specifications, and approved shop drawings, MS, FQP, ICL and CCL.
- c) Ensure necessary coordination with all involved for timely completion of job.
- d) Will attend all site review and progress review meeting time to time.
- e) Overall responsibility of the site.



**WORK METHOD STATEMENT -  
WIRING**

**एम एम आर डी ए  
MMRDA**
**5.2 Site Engineer:**

- a) Timely provision of relevant and complete information, approved documents and instructions to site execution / installation team.
- b) Proper execution of works as per approved documents, MS, Drawings.
- c) The implementation of the procedures mentioned in MS with the help of concerned site engineer/ site supervisors.
- d) To carry out site work activities with regards to quality and safety requirements coordinating with site quality and safety representatives.

**5.3 Site Supervisor:**

- a) To ensure site execution works as per approved shop drawings, specifications and as per site conditions/clearance.
- b) Before start the work, pre-survey shall be done for the work front availability and safe working place.
- c) Responsible for assigned work execution at site as per time schedule.
- d) Coordination with site engineer for to resolve any critical issues addressed at the time of execution and during measurements.
- e) To monitor sub-contractor's technician, helper for work execution and issue material from stores as per requirement.
- f) Timely coordination with store in-charge for material availability.
- g) After completion of execution for assigned area, quality checks will be performed and recorded in Installation checklists. Then, same area is offered for inspection to site quality engineer.

**5.4 Site Quality Engineer:**

- a) Identified Site Quality Engineer is responsible for preparation of project specific quality documents in consultation and support from regional quality representative.
- b) Responsible for communicating with all site staff about Quality requirements and responsible for reviewing all related documents.
- c) Responsible for conducting Tool Box talk meeting along with Site In charge & Site Engineers for training to site technicians staff
- d) Responsible for incoming material inspection & accordingly raising MIR (Material Inspection Request) for PMC/ Client inspection
- e) Responsible for daily site audits and recording of observation with photographs
- f) Responsible for installation inspection and verification of Installation checklists filled by Site supervisors
- g) Raising the SIR (Site Inspection Request) for PMC/ Client inspection
- h) Responsible for corrective actions in coordination with Project Manager & Site Engineer and close the non-conformity identified during quality audits





**STRABAG****WORK METHOD STATEMENT -  
WIRING****एम एम आर डी ए  
MMRDA****6.0 Tools & Equipment's**

Tools and equipment required for this activity as per listed below:

- 6.1 Electricians Toolbox
- 6.2 Spanners / Hand tools
- 6.3 Crimping Tools
- 6.4 Safety gears

**7.0 Installation Procedure and Methodology****7.1 Preparation Work**

Before the commencement of installation, the following are required to be carried out:

- 7.1.1 Check sufficient storage area is available in the store.
- 7.1.2 Check that all the allocated work area is clear, and fronts are ready for safe installation.
- 7.1.3 Wiring layout and routes shall be approved before starting of work in line with conduit layout and cable layout.
- 7.1.4 Ensure availability of all materials as per approved documents.
- 7.1.5 All materials required as per approved layouts shall be checked for necessary approvals like make, size, model, type, color etc.
- 7.1.6 All along the route is checked for cleanliness and thoroughness.

**7.2 Installation of Wires**

- 7.2.1 Clean the conduit pipe and ensure that there are no sharp edges/ obstacles to damage the wire
- 7.2.2 Install the wires/flexible cables as per approved drawings
- 7.2.3 All the routing / wiring shall be drawn from respective distribution boxes to point of utilization and is looped from live and neutral terminals of accessories for circuit continuation as per approved drawings.
- 7.2.4 Final connections in luminaires and heat producing / emitting equipment shall be made using heat resistant flexible cables.
- 7.2.5 The specified wire sizes shall be followed as per approved load schedule/shop drawing.
- 7.2.6 Proper colour coding shall be followed for phase, neutral, earth wires as per standard electrical codes and respective approved shop drawings, specifications.
- 7.2.7 Circuit Wire pulling through the conduits shall be done using steel wire as per the approved methodology



**STRABAG****WORK METHOD STATEMENT -  
WIRING****एम एम आर डी ए  
MMRDA**

- 7.2.8 Each circuit shall be neatly dressed / bunched at intervals
- 7.2.9 Wires terminated inside DB or inside switch box shall be provided with lugs, insulation sleeve
- 7.2.10 After dressing of wires ferrules shall be provided at phase, neutral and earth wire ends as per approved shop drawing/SLD.



- 7.2.11 The cables or wires shall not be jointed. These should be continuous.
- 7.2.12 Wires shall not exceed the capacity of the conduit or trunking. Installations shall be strictly following the standard rules and regulations.
- 7.2.13 Wires shall be combed as installation proceeds and neutral, earth conductor shall be run with the phase wires of that circuit.
- 7.2.14 Wires of one circuit shall run in the same conduit.
- 7.2.15 Two separate phase circuits/wires shall not run through separate conduits.
- 7.2.16 Do not install wiring of more than one phase in an outlet box or switch box other than one designated for multiphase use.



**STRABAG****WORK METHOD STATEMENT -  
WIRING****एम एम आर डी ए  
MMRDA**

- 7.2.17 Where the distribution is for single phase loads only, conductors for these phases shall be drawn in the same conduit
- 7.2.18 In case of three phase loads, separate conduits shall be run from the distribution boards to the load points.
- 7.2.19 The colour coding of wires / cables shall follow till the terminating point within the distribution boards and equipments.
- 7.2.20 Total number of wires run in a conduit should not exceed as per the installation standards. Refer following table:

**TABLE 6 MAXIMUM PERMISSIBLE NUMBER OF 250 V GRADE SINGLE-CORE CABLES THAT CAN BE DRAWN INTO RIGID STEEL CONDUITS**  
( Clauses B-5.7, B-1.9 and B-5.1.1 )

SIZE OF CABLE		SIZE OF CONDUIT, mm													
Nominal Cross-Sectional Area, mm <sup>2</sup>	Number and Diameter of Wires, mm	16		20		25		32		40		50		63	
		S	B	S	B	S	B	S	B	S	B	S	B		
1.0	1/1.12*	5	4	7	5	13	10	20	14	—	—	—	—	—	—
1.5	1/1.40	4	3	7	5	12	10	20	13	—	—	—	—	—	—
2.5	{ 1/1.80 3/1.06*	3	2	0	5	10	8	18	12	—	—	—	—	—	—
4	{ 1/2.24 3/0.85*	3	2	4	3	7	6	12	10	—	—	—	—	—	—
6	{ 1/2.80 2/1.06*	2	—	3	2	6	5	10	8	—	—	—	—	—	—
10	{ 1/3.55† 2/1.40*	—	—	2	—	5	4	6	5	—	—	—	—	—	—
16	2/1.70	—	—	—	—	2	—	4	3	2	6	—	—	—	—
25	2/2.24	—	—	—	—	—	—	3	2	5	4	6	6	9	7
35	2/2.50	—	—	—	—	—	—	2	—	4	3	7	5	8	6
50	{ 2/3.00† 1/3.10	—	—	—	—	—	—	—	—	2	—	5	4	6	5

NOTE 1 — The table shows the maximum capacity of conduits for the simultaneous drawing of cables. The columns headed S apply to runs of conduit which have distance not exceeding 4.25 m between draw-in boxes, and which do not deflect from the straight by an angle of more than 15°. The columns headed B apply to runs of conduit which deflect from the straight by an angle of more than 15°.

NOTE 2 — In case an inspection type draw-in box has been provided and if the cable is first drawn through one straight conduit, then through the draw-in box, and then through the second straight conduit, such systems may be considered as that of a straight conduit even if the conduit deflects through the straight by more than 15°.

\* For copper conductors only.  
† For aluminium conductors only.



**STRABAG****WORK METHOD STATEMENT -  
WIRING**

**एम एम आर डी ए  
MMRDA**

**TABLE 7 MAXIMUM PERMISSIBLE NUMBER OF 250 VOLTS GRADE SINGLE-CORE  
CABLES THAT MAY BE DRAWN INTO RIGID NON-METALLIC CONDUITS**  
(Class B-3.7, B-4.9 and B-5.3.2)

SIZE OF CABLE		SIZE OF CONDUIT (mm)					
Nominal Cross-Sectional Area mm <sup>2</sup>	Number and Diameter (to mm) of Wires	16	20	25	32	40	50
		NUMBER OF CABLES, Max					
1.0	1/1.12*	5	7	13	20	—	—
1.5	1/1.40	4	6	10	14	—	—
2.5	( 1/1.80 ) ( 3, 1.06* )	3	5	10	14	—	—
4	( 1/2.24 ) ( 7/0.85* )	2	3	6	10	14	—
6	( 1/2.80 ) ( 7/1.40* )	—	2	5	9	11	—
10	( 1/3.53† ) ( 7/1.40* )	—	—	4	7	9	—
16	7/1.70	—	—	2	4	5	12
25	7/2.24	—	—	—	2	2	6
35	7/2.50	—	—	—	—	2	5
50	7/3.00† 19/1.80	—	—	—	—	2	5

\*For copper conductors only.

†For aluminium conductors only.

7.2.21 Check for number of wires run in conduit should not exceed as per the installation standards. Refer below table:

**7.3 Final Installation of Conduits**

7.3.1 All pull boxes, junction boxes fixed on the wall with screws in the route of conduit shall be provided with cover after pulling the wires.

**8.0 Design & Drawings**

Manufacturers Catalogues and Final approved layout drawings.

**9.0 Quality**

Procedures described in the Method Statement (MS) for Installation of point wiring works shall be followed and use following related Quality Formats:

- Inspection Testing Plan (ITP)
- Installation Checklist (ICL)
- Commissioning Checklist (CCL)

**10.0 Distribution**

Distribution of documents shall be as per contractual Specification and agreed protocols



**STRABAG****WORK METHOD STATEMENT -  
CONDUTING** **एम एम आर डी ए  
MMRDA****MUMBAI TRANS HARBOUR LINK PROJECT (MTHL)****IFB No.: MMRDA/ENG1/0002561:**

Document No.	Document Name		Document Revision
0009	<b>WORK METHOD STATEMENT - CONDUTING</b>		R00
	<b>Prepared By</b>	<b>Checked By</b>	<b>Approved By</b>
<b>Name</b>	Sandeep	Mubashshir	Anuj
<b>Designation</b>	Manager	DGM	GM
<b>Date</b>	29.11.2021	29.11.2021	29.11.2021



**STRABAG****WORK METHOD STATEMENT -  
CONDUTING****एम एम आर डी ए  
MMRDA****1.0 Purpose**

The purpose of generating this method statement is to define the procedure step by step to implement the correct practices for installation of Metal & PVC Conduiting works.

**2.0 Scope**

This method statement refers to various work procedures contained within Strabag and Design / Drawing / Contractual specifications / Customer Quality Requirements which explains and covers the installation of Metal & PVC Conduiting works.

**3.0 Reference**

- 3.1 Project Plan
- 3.2 Contract Technical Specifications
- 3.3 Approved Technical Data Sheets
- 3.4 Design Intent Drawings & Approved Shop Drawings
- 3.5 Manufacturers Catalogues & Recommendations

**4.0 Abbreviations:**

Project: MTHL  
 Client: MMRDA  
 Contractor: **STRABAG**  
 MS – Method Statement  
 FQP – Field Quality Plan  
 ICL – Installation Check List  
 CCL – Commissioning Check list  
 MHS – Material Handling System Checklist  
 MQAP – Manufacturer Quality Assurance Plan

**5.0 Responsibilities****5.1 Project Manager (Site In-charge):**

- a) Ensure all required submittals area made and required plant, tools, material manpower is available in timely manner.
- b) Ensure all execution of works area carried out according to approvals, contract specifications, and approved shop drawings, MS, FQP, ICL and CCL.
- c) Ensure necessary coordination with all involved for timely completion of job.
- d) Will attend all site review and progress review meeting time to time.
- e) Overall responsibility of the site

**5.2 Site Engineer:**

**STRABAG****WORK METHOD STATEMENT -  
CONDUTING** **एम एम आर डी ए  
MMRDA**

- Timely provision of relevant and complete information, approved documents and instructions to site execution / installation team.
- Proper execution of works as per approved documents, MS, Drawings.
- The implementation of the procedures mentioned in MS with the help of concerned site engineer/ site supervisors.
- To carry out site work activities with regards to quality and safety requirements coordinating with site quality and safety representatives.

**5.3 Site Supervisor:**

- To ensure site execution works as per approved shop drawings, specifications and as per site conditions/clearance.
- Before start the work, pre-survey shall be done for the work front availability and safe working place.
- Responsible for assigned work execution at site as per time schedule.
- Coordination with site engineer for to resolve any critical issues addressed at the time of execution and during measurements.
- To monitor sub-contractor's technician, helper for work execution and issue material from stores as per requirement.
- Timely coordination with store in-charge for material availability.
- After completion of execution for assigned area, quality checks will be performed and recorded in Installation checklists. Then, same area is offered for inspection to site quality engineer.

**5.4 Site Quality Engineer:**

- Identified Site Quality Engineer is responsible for preparation of project specific quality documents in consultation and support from regional quality representative.
- Responsible for communicating with all site staff about Quality requirements and responsible for reviewing all related documents.
- Responsible for conducting Tool Box talk meeting along with Site Incharge & Site Engineers for training to site technicians staff
- Responsible for incoming material inspection & accordingly raising MIR (Material Inspection Request) for PMC/ Client inspection
- Responsible for daily site audits and recording of observation with photographs
- Responsible for installation inspection and verification of Installation checklists filled by Site supervisors
- Raising the SIR (Site Inspection Report) for PMC/ Client inspection
- Responsible for corrective actions in coordination with Project Manager & Site Engineer and close the non-conformity identified during quality audits



**STRABAG****WORK METHOD STATEMENT -  
CONDUTING****एम एम आर डी ए  
MMRDA****6.0 Tools & equipment's**

Tools and equipment required for this activity as per listed below:

- 6.1 Fitter Tool Box
- 6.2 Electricians Tool Box
- 6.3 Pipe bending machine
- 6.4 Threading cutting die
- 6.5 Vise Holder
- 6.6 Spanners / Hand tools
- 6.7 Hack saw
- 6.8 Level indicator

**7.0 Preparation Work**

Before the commencement of installation, the following are required to be carried out:

- 7.0.1 Check sufficient storage area is available in the store.
- 7.0.2 Check that all the allocated work area is clear and fronts are ready for safe installation.
- 7.0.3 Conduit layout and routes shall be approved before starting of work.
- 7.0.4 Ensure availability of all materials as per approved documents.
- 7.0.5 All materials required as per approved layouts shall be checked for necessary approvals like make, size, model, type etc.
- 7.0.6 Conduit routes shall be chosen for easy, straight runs with a minimum of bends and crossings.
- 7.0.7 Outlet boxes for housing accessories shall be used as draw boxes.
- 7.0.8 All conduits shall be kept clear from gas and water pipes. Conduits shall be 150mm away from gas pipes.
- 7.0.9 Electrical and mechanical continuity shall be maintained throughout all conduit joints termination. Conduit threads shall be thoroughly cleaned and the conduits tightly screw. The conduit system shall be watertight after installation.





**STRABAG****WORK METHOD STATEMENT -  
CONDUITING****एम एम आर डी ए  
MMRDA**

7.0.10 Conduit shall be bent cold with an approved type of bending block or bending machine without altering the dimensions of their sections.

7.0.11 Bends shall be made with as large a radius as the conduit within the building permits.

### 7.1 Installation of Concealed Conduiting (On Slab & Wall)

7.1.1 Conduits concealed in wall shall be laid by chasing of brickwork with position marked as per approved shop drawing using marking thread/ marking powder.



7.1.2 The chases shall be of width (8 to 10mm more) to accommodate the required number of conduits and of depth (5 to 8 mm more) to permit full thickness of plaster over conduits.

7.1.3 The conduit pipes are fixed using saddles at an interval of 500mm distance along the chased length

7.1.4 For chases more than 75mm width, a chicken wire mesh shall be provided for the full length & width of chased area in the plaster to prevent cracking by the civil agencies.



**STRABAG****WORK METHOD STATEMENT -  
CONDUITING****एम एम आर डी ए  
MMRDA**

- 7.1.5 Metal back box shall be covered with masking tape on backside before fixing to avoid seepage of water after concealing of back box



- 7.1.6 Conduit drop shall be terminated to back box knock out entry hole with the use of adequate sizes of adaptors.
- 7.1.7 Back boxes openings shall be covered before backfilling of cement mortar to avoid blocking of back boxes

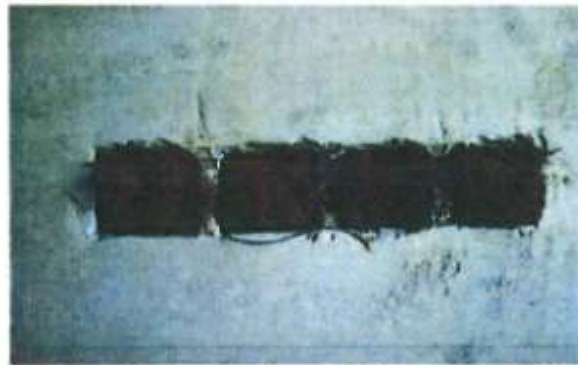

## 7.2 Installation of Surface Conduiting (On Ceiling and Wall)

- 7.2.1 Mark the conduit route with Line -Dori for location of saddles & points as per approved shop drawing



**STRABAG****WORK METHOD STATEMENT -  
CONDUTING****एम एम आर डी ए  
MMRDA**

7.2.2 Suitable size of spacer saddles of approved make shall be fixed to the final structural surface along the conduit route at the intervals as below:

- For metal conduits 150-200cm horizontally and 200-300cm vertically
- For Plastic conduits 60-100cm horizontally and 100-150cm vertically
- Also, at 150mm on either side of fittings like Junction boxes, Inspection bends, Solid Bends, Straight coupler etc.

7.2.3 Hole on concrete or brickwork for fixing the saddles shall be made by electric drill machine.



**STRABAG****WORK METHOD STATEMENT -  
CONDUTING****एम एम आर डी ए  
MMRDA**

- 7.2.4 All surface conduits shall be run in a vertical or horizontal direction.
- 7.2.5 The conduit shall be properly earthed with system earthing as per approved earthing layout
- 7.2.6 Conduits used for routing - Make sure that inside diameter of conduit is at least 1.5 times of the outside diameter of cable wire or bunch of cable wires that are going to be pulled through

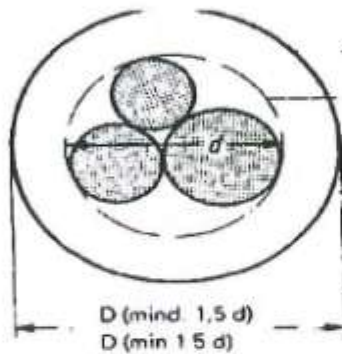

**D = Inside Diameter of conduit**  
**d = Outside Diameter of Cable wire/Bunch of cable wire**

- 7.2.7 For cutting conduits as per required length, use vise holder and hacksaw tool
- 7.2.8 Sharp edges of metal conduits shall be smoothed from inside & outside at pipe ends



**STRABAG****WORK METHOD STATEMENT -  
CONDUITING****एम एम आर डी ए  
MMRDA**

7.2.9 For metal conduits, bends shall be made using bending machine and check bends for correctness as follows



7.2.10 Conduit bends shall be design so as conduit bending radius = 10 times of conduit outside diameter. Refer as following:

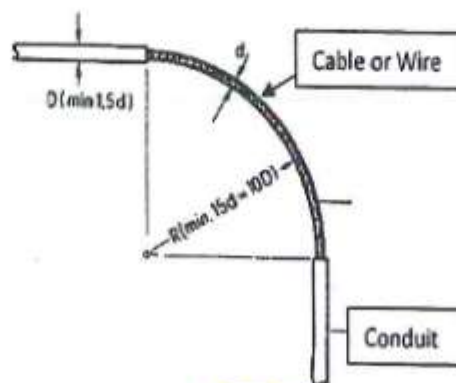

**STRABAG****WORK METHOD STATEMENT -  
CONDUTING****एम एम आर डी ए  
MMRDA**

- 7.2.11 For Gi Conduits - Conduit threading areas shall be covered with anti-corrosive paint before fixing at location or inserting into accessories
- 7.2.12 For MS Paint - Conduit threading areas shall be covered with anti-corrosive paint of colour similar to base conduit before fixing at location or inserting into accessories



- 7.2.13 Flexible conduits shall be used to take connections from an accessible location and end connections to motor terminal boxes.
- 7.2.14 In damp areas like pump room and external areas, PVC covered metallic flexible conduits shall be used.
- 7.2.15 Expansion couplers shall be used wherever conduit passes through building expansion joints.

### 7.3 Final Installation of Conduits

- 7.3.1 Conduits shall be installed, concealed in building claddings or above suspended ceilings in finished areas and may be installed exposed only in unfinished areas.
- 7.3.2 Clean the external surfaces of the conduit and terminal boxes. Checking for any damage etc.
- 7.3.3 Check the tightness of all installations.



**STRABAG****WORK METHOD STATEMENT -  
CONDUITING****एम एम आर डी ए  
MMRDA**

7.3.4 All pull boxes, junction boxes fixed on the wall with screw in the route of conduit shall be provided with cover after pulling the wires.

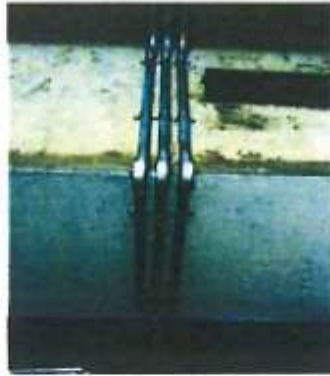

## 8.0 Design & Drawings

Manufacturers Catalogues and Final approved layout drawings.

## 9.0 Quality

Procedures described in the Method Statement (MS) for Installation of Metal & PVC Conduiting works shall be followed and use following related Quality Formats:

- Inspection Testing Plan (ITP)
- Installation Checklist (ICL)
- Commissioning Checklist (CCL)

## 10.0 Distribution

Distribution of documents shall be as per contractual Specification and agreed protocols.

\*\*\*\*\*



Page 11 | 11

**STRABAG****WORK METHOD STATEMENT –  
EARTHING WORK****एम एम आर डी ए  
MMRDA****MUMBAI TRANS HARBOUR LINK PROJECT (MTHL)****IFB No.: MMRDA/ENG1/0002561:**

Document No.	Document Name		Document Revision
0010	<b>WORK METHOD STATEMENT - EARTHING WORK</b>		R00
	<b>Prepared By</b>	<b>Checked By</b>	<b>Approved By</b>
<b>Name</b>	Sandeep	Mubashshir	Anuj
<b>Designation</b>	Manager	DGM	GM
<b>Date</b>	29.11.2021	29.11.2021	29.11.2021





**WORK METHOD STATEMENT –  
EARTHING WORK**

**1.0 Purpose**

The purpose of generating this method statement is to define the procedure step by step to implement the correct practices for installation of Earthing Works.

**2.0 Scope**

This method statement refers to various work procedures contained within Strabag and Design / Drawing / Contractual specifications / Customer Quality Requirements which explains and covers the installation of Earthing Works.

**3.0 Reference**

- 3.1 Project Plan
- 3.2 Contract Technical Specifications
- 3.3 Approved Technical Data Sheets
- 3.4 Design Intent Drawings & Approved Shop Drawings
- 3.5 Manufacturers Catalogues & Recommendations

**4.0 Abbreviations:**

Project: MTHL  
 Client: MMRDA  
 Contractor: **STRABAG**  
 MS – Method Statement  
 FQP – Field Quality Plan  
 ICL – Installation Check List  
 CCL – Commissioning Check list  
 MHS – Material Handling System Checklist  
 MQAP – Manufacturer Quality Assurance Plan

**5.0 Responsibilities**
**5.1 Project Manager (Site In-charge):**

- a) Ensure all required submittals area made and required plant, tools, material manpower is available in timely manner.
- b) Ensure all execution of works area carried out according to approvals, contract specifications, and approved shop drawings, MS, FQP, ICL and CCL.
- c) Ensure necessary coordination with all involved for timely completion of job.
- d) Will attend all site review and progress review meeting time to time.
- e) Overall responsibility of the site.



**STRABAG****WORK METHOD STATEMENT –  
EARTHING WORK****एम एम आर डी ए  
MMRDA****5.2 Site Engineer:**

- Timely provision of relevant and complete information, approved documents and instructions to site execution / installation team.
- Proper execution of works as per approved documents, MS, Drawings.
- The implementation of the procedures mentioned in MS with the help of concerned site engineer/ site supervisors.
- To carry out site work activities with regards to quality and safety requirements coordinating with site quality and safety representatives.

**5.3 Site Supervisor:**

- To ensure site execution works as per approved shop drawings, specifications and as per site conditions/clearance.
- Before start the work, pre-survey shall be done for the work front availability and safe working place.
- Responsible for assigned work execution at site as per time schedule.
- Coordination with site engineer for to resolve any critical issues addressed at the time of execution and during measurements.
- To monitor sub-contractor's technician, helper for work execution and issue material from stores as per requirement.
- Timely coordination with store in-charge for material availability.
- After completion of execution for assigned area, quality checks will be performed and recorded in Installation checklists. Then, same area is offered for inspection to site quality engineer.

**5.4 Site Quality Engineer:**

- Identified Site Quality Engineer is responsible for preparation of project specific quality documents in consultation and support from regional quality representative.
- Responsible for communicating with all site staff about Quality requirements and responsible for reviewing all related documents.
- Responsible for conducting Tool Box talk meeting along with Site Incharge & Site Engineers for training to site technicians staff
- Responsible for incoming material inspection & accordingly raising MIR (Material Inspection Request) for PMC/ Client inspection
- Responsible for daily site audits and recording of observation with photographs
- Responsible for installation inspection and verification of Installation checklists filled by Site supervisors

**STRABAG****WORK METHOD STATEMENT --  
EARTHING WORK****एम एम आर डी ए  
MMRDA**

- g) Raising the SIR (Site Inspection Request) for PMC/ Client inspection
- h) Responsible for corrective actions in coordination with Project Manager & Site Engineer and close the non-conformity identified during quality audits

**6.0 Tools & Equipment's**

Tools and equipment required for this activity as per listed below:

- 6.1 Safety gears Strip bending machine
- 6.2 Welding Machine
- 6.3 Spanners / Hand tools
- 6.4 Hack saw
- 6.5 Drilling Machine
- 6.6 C Clamp.
- 6.7 Safety equipment for welding i.e., Goggles, gloves, welding glass.
- 6.8 Sandpaper
- 6.9 Hammer.
- 6.10 Petroleum jelly.
- 6.11 Screwdriver set.
- 6.12 Black paint.
- 6.13 Painting brush.
- 6.14 Cutter
- 6.15 Continuity tester
- 6.16 Zinc rich paint
- 6.17 Electrical & Fitter toolbox
- 6.18 RCC Block Masonry
- 6.19 Civil Excavating tools for Earth Pit Preparation
- 6.20 Earth Tester

**7.0 Installation Procedure and Methodology****7.1 Preparation Work**

Before the commencement of installation, the following are required to be carried out:

- 7.1.1 Earthing conductor will be checked physically for its proper sizes, galvanizing (As per approved Material Submittal/TDS).
- 7.1.2 The Gi/Cu flats will be straightened and stored near field location with supports provided to raise above floor level.



**STRABAG****WORK METHOD STATEMENT –  
EARTHING WORK**

**एम एम आर डी ए  
MMRDA**

7.1.3 Straighten the hot dip galvanized / G.I earthing strips using bench hammer & Cu earth strips using Plastic or Rubber mallet



- 7.1.4 Check that all the allocated earthing installation position is clear, or fronts are ready for installation.
- 7.1.5 Earthing layout and routes shall be approved before starting of work.
- 7.1.6 Earthing routes shall be chosen for easy, straight runs with a minimum of bends and crossings.
- 7.1.7 Earthing grid shall be kept 600mm below the Finish Ground Level.
- 7.1.8 Overlapping of the two strips shall be as per width of the earthing strip.
- 7.1.9 Welding area shall be minimum 150 % of the cross-section of the earthing strip

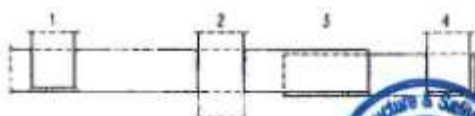
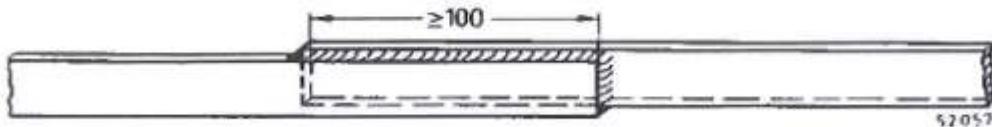

- |   |                       |
|---|-----------------------|
| 1 | Branch Connection     |
| 2 | Cross-over Connection |
| 3 | Linear Connection     |
| 4 | Angle Connection      |



**STRABAG****WORK METHOD STATEMENT –  
EARTHING WORK****एम एम आर डी ए  
MMRDA****7.1.10 Earthing strip welding joints shall be made as follows:**

- i. Clean the earth strip jointing surfaces and align the cutting edges as below –



- ii. Take the overlap piece of earth strip (i.e., approx. 100mm or twice the width of earth strips) and keep it at center on jointing surfaces, as shown below -



- iii. Hold the earth strip welding joint area with "C" Clamp to avoid gaps in between after welding performed, as shown below –

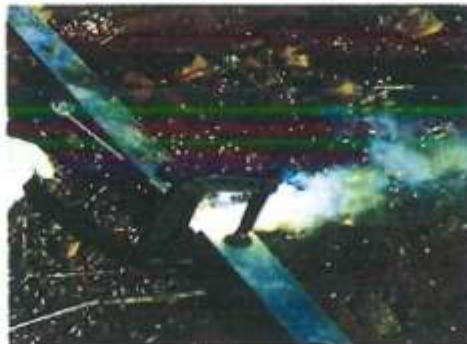

- iv. Perform the earth strip joint welding with qualified welders with using proper safety PPE's



**STRABAG****WORK METHOD STATEMENT –  
EARTHING WORK****एम एम आर डी ए  
MMRDA**

- v. Remove the Welding slag and spatters deposited near earth strip jointing area, with the help of wire brush, as shown below -



- vi. Cover the welding joint area with anti-corrosive (zinc rich) paint to avoid oxidation, as shown below -



7.1.11 Electrical and mechanical continuity shall be maintained throughout all earthing Joints.

7.1.12 Screw Joints above ground should be overlapped as shown below. Straight joints require two screws while only one screw is used for T joints.



**STRABAG****WORK METHOD STATEMENT –  
EARTHING WORK****एम एम आर डी ए  
MMRDA**

Tightening Torque.

(Up to 30mm thickness) M10 = 20Nm

(From 40mm thickness) M12 = 40Nm

7.1.13 All underground earthing joints shall be painted by black bitumen compound and all exposed joint shall be painted with zinc rich paint

**Corrosion Protection:**

Material	Method of Jointing	Corrosion Protection	
		In Soil	In Concrete
Copper Strip	Screwed Joint	Corrosion protective binding	-
Galvanized Steel Strip	Welded Joint	Zinc paste or corrosion protective binding	Zinc paste or corrosion protective binding

**7.2 Installation of Underground Earthing**

- 7.2.1 Excavation shall be done 600 mm below the final ground level or as per the approved layout drawings.
- 7.2.2 Welding shall be done as per the specification and two welding strip should be held with the help of C clamp during the welding to avoid the gap between two earthing strips.
- 7.2.3 Black bitumen compound should be applied on all the earthing joints to avoid the rusting of the earthing strip at welded portion.
- 7.2.4 Earthing or return of the welding transformer should be connected directly to the object which is to be welded

**7.3 Installation of Exposed Earthing**

- 7.3.1 Welding shall be done as per the specification and two welding strip should be held with the help of C clamp during the welding to avoid the gap between two earthing strip.
- 7.3.2 If welding is not applicable, then overlap joint shall be nut-bolted type. Holes to be made with the help of drill machine and sufficient size and number of Gi bolts to be provided along with spring washer and nuts for proper contact of the two Earthing strip.



**STRABAG****WORK METHOD STATEMENT –  
EARTHING WORK****एम एम आर डी ए  
MMRDA**

- 7.3.3 All exposed welding joint shall be painted with cold galvanized zinc rich paint.
- 7.3.4 Welding transformer / Welding Machine shall be capable of generating minimum 200Amps current during the welding.
- 7.3.5 Earthing or return of the welding transformer should be connected directly to the Object which is to be welded or return shall be through proper size of conductors.
- 7.3.6 All surface Earthing strip shall be run in a vertical or horizontal direction.
- 7.3.7 Proper bending of the earthing strip shall be done with the help of bending machine.
- 7.3.8 Earthing strip running on walls shall be clamped with the help of proper clamp with an interval specified in approved drawings/documents.

**7.4 Installation of Earthing Pits**

- 7.4.1 Prepare the earthing electrode as per the drawings
- 7.4.2 Excavate the soil minimum 3.0m depth or as per approved drawings
- 7.4.3 Excavated soil should be kept 1.5 mtr away from the excavated pit
- 7.4.4 Excavated area should be barricaded physically
- 7.4.5 Place the earthing electrode in the excavated hole for the earthing pit.
- 7.4.6 Fill the charcoal and salt in earth pits in alternate layers or as per IS guidance.
- 7.4.7 The area covered by the layers of charcoal and salt shall be of minimum 150mm from all the side of the earth electrode.
- 7.4.8 Fill the balance area by soil.
- 7.4.9 Pour some quantity of water through the funnel to make the compound Homogeneous with the earth.
- 7.4.10 Ramp the excavated soil and construct the chamber as per drawing.
- 7.4.11 Test link shall be provided to earth electrode for testing purpose.
- 7.4.12 Resistance of earth pit and grid shall be measured & maintained as per Technical Specification & IS 3043.

**7.5 Installation of Chemical Earth Pits**

- 7.5.1 The Chemical earth pits shall be installed as per Manufacturer recommendations and their installation instructions
- 7.5.2 Make a bore of 12" to 16" in diameter upto electrode length of 2/3 meters (Refer approved Earthing layout and manufacturer manual for dimension details)
- 7.5.3 Fill the bottom 4" of bore with the supplied BFC (Back fill compound)
- 7.5.4 Vertically place the electrode in the center of the pit
- 7.5.5 Fill the cavity around the electrode with supplied BFC (Back fill compound)
- 7.5.6 Ensure there are no air gaps in the BFC filled cavity region
- 7.5.7 Now pour sufficient water into the earth pit until BFC takes the form of paste / mud





**STRABAG****WORK METHOD STATEMENT –  
EARTHING WORK****एम एम आर डी ए  
MMRDA**

- 7.5.8 Allow the pit to absorb water and settle down
- 7.5.9 Test link shall be provided to earth electrode for testing purpose
- 7.5.10 Resistance of earth pit and grid shall be measured & maintained as per Technical Specification & IS 3043

**7.6 Installation of Earthing Conductor and Equipment Earthing**

- 7.6.1 Neutral points of transformer shall be solidly earthed / earthed by two separate copper strips to two separate earth electrodes.
- 7.6.2 The HV Switchgear, Main LV panel including Inverter panel, UPS shall be connected to earthing grid of the System as specified in the Specifications and approved drawings.
- 7.6.3 The metallic case of all equipment shall be earthed by two separate connections to earthing system.
- 7.6.4 The cable tray shall be earthed at minimum two places by GS flats to earthing system, the distance between earthing points shall not exceed 30 meters.
- 7.6.5 Earthing conductor shall be buried at least 2000mm outside the fence of electrical installations. Every alternate post of the fences and all gates shall be connected to earthing grid by one lead.
- 7.6.6 Minimum earth coverage of 300 mm shall be provided between earth conductors and the bottom of trench/foundation/underground pipes at crossings.
- 7.6.7 Earthing conductor crossings, the road can be installed in pipes.
- 7.6.8 Wherever earthing conductor crosses or runs at less than 300 mm distance along metallic structures such as gas, water, steam pipelines, steel reinforcement in concrete, it shall be bonded to the same.
- 7.6.9 Earthing for the equipment viz Data processing installation & lighting Fixtures shall be done per the approved drawing or IS.
- 7.6.10 The size of conductors for Body Earthing shall be as per drawings.
- 7.6.11 Earthing of the multi core cable shall be earthed with earthing system at both the terminated ends.
- 7.6.12 Proper hardware's will be used for jointing.
- 7.6.13 All HT, LT Panels and Transformer body earthing is done as per the drawing.
- 7.6.14 Earth resistance for the system below and above 250 volts shall be as per approved drawings/ specification/ IS 3043
- 7.6.15 All Individual Earth pits resistance and grid resistance must be checked, and the values shall be in line with approved specification/IS 3043
- 7.6.16 Hume Pipes shall be used for the earth conductor passing below road crossing.



**STRABAG****WORK METHOD STATEMENT –  
EARTHING WORK****एम एम आर डी ए  
MMRDA****8.0 Design & Drawings**

Manufacturers Catalogues and Final approved layout drawings.

**9.0 Quality**Procedures described in the Method Statement (MS) for Installation of Earthing works shall be followed and use following related Quality Formats Attachments as follows:

- Method Statement (MS)
- Installation Checklist (ICL)
- Commissioning Checklist (CCL)

**10.0 Distribution**

Distribution of documents shall be as per contractual Specification and agreed protocols.

\*\*\*\*\*



Page 11 | 11



**STRABAG**

WORK METHOD STATEMENT –  
INSTTALATION OF LIGHTNING  
ARRESTOR



### MUMBAI TRANS HARBOUR LINK PROJECT (MTHL)

**IFB No.: MMRDA/ENG1/0002561:**

Document No.	Document Name		Document Revision
0011	WORK METHOD STATEMENT - INSTTALATION OF LIGHTNING ARRESTOR		R00
	<b>Prepared By</b>	<b>Checked By</b>	<b>Approved By</b>
<b>Name</b>	Sandeep	Mubashshir	Anuj
<b>Designation</b>	Manager	DGM	GM
<b>Date</b>	29.11.2021	29.11.2021	29.11.2021





**WORK METHOD STATEMENT –  
INSTALLATION OF LIGHTNING  
ARRESTOR**



### 1.0 Purpose

The purpose of generating this method statement is to define the procedure step by step to implement the correct practices for installation of Lightning Protection System.

### 2.0 Scope

This method statement refers to various work procedures contained within Stragab and Design / Drawing / Contractual specifications / Customer Quality Requirements which explains and covers the installation of Lightning Protection System.

### 3.0 Reference

- 3.1 Project Plan
- 3.2 Contract Technical Specifications
- 3.3 Approved Technical Data Sheets
- 3.4 Design Intent Drawings & Approved Shop Drawings
- 3.5 Manufacturers Catalogues & Recommendations

### 4.0 Abbreviations:

Project: MTHL  
Client: MMRDA  
Contractor: **STRABAG**  
MS – Method Statement  
FQP – Field Quality Plan  
ICL – Installation Check List  
CCL – Commissioning Check list  
MHS – Material Handling System Checklist  
MQAP – Manufacturer Quality Assurance Plan

### 5.0 Responsibilities

#### 5.1 Project Manager (Site In-charge):

- a) Ensure all required submittals area made and required plant, tools, material manpower is available in timely manner.
- b) Ensure all execution of works area carried out according to approvals, contract specifications, and approved shop drawings, MS, FQP, ICL and CCL.
- c) Ensure necessary coordination with all involved for timely completion of job.
- d) Will attend all site review and progress review meeting time to time.
- e) Overall responsibility of the





**WORK METHOD STATEMENT –  
INSTALLATION OF LIGHTNING  
ARRESTOR**



**5.2 Site Engineer:**

- Timely provision of relevant and complete information, approved documents and instructions to site execution / installation team.
- Proper execution of works as per approved documents, MS, Drawings.
- The implementation of the procedures mentioned in MS with the help of concerned site engineer/ site supervisors.
- To carry out site work activities with regards to quality and safety requirements coordinating with site quality and safety representatives.

**5.3 Site Supervisor:**

- To ensure site execution works as per approved shop drawings, specifications and as per site conditions/clearance.
- Before start the work, pre-survey shall be done for the work front availability and safe working place.
- Responsible for assigned work execution at site as per time schedule.
- Coordination with site engineer for to resolve any critical issues addressed at the time of execution and during measurements.
- To monitor sub-contractor's technician, helper for work execution and issue material from stores as per requirement.
- Timely coordination with store in-charge for material availability.
- After completion of execution for assigned area, quality checks will be performed and recorded in Installation checklists. Then, same area is offered for inspection to site quality engineer.

**5.4 Site Quality Engineer:**

- Identified Site Quality Engineer is responsible for preparation of project specific quality documents in consultation and support from regional quality representative.
- Responsible for communicating with all site staff about Quality requirements and responsible for reviewing all related documents.
- Responsible for conducting Tool Box talk meeting along with Site Incharge & Site Engineers for training to site technicians staff
- Responsible for incoming material inspection & accordingly raising MIR (Material Inspection Request) for PMC/ Client inspection
- Responsible for daily site audits and recording of observation with photographs
- Responsible for installation inspection and verification of Installation checklists filled by Site supervisors



**WORK METHOD STATEMENT –  
INSTALLATION OF LIGHTNING  
ARRESTOR**



- g) Raising the SIR (Site Inspection Request) for PMC/ Client inspection
- h) Responsible for corrective actions in coordination with Project Manager & Site Engineer and close the non-conformity identified during quality audits

## 6.0 Tools & Equipment

Tools and equipment required for this activity as per listed below:

- 6.1 Mobile Crane/Tower Crane with the capacity at least two times of the Load to be unloaded
- 6.2 Spanners / Hand tools
- 6.3 Nylon Belts and Nylon rope with test certificates
- 6.4 Slings / Shackles with test certificates
- 6.5 Level indicator
- 6.6 Plumb Bob
- 6.7 Crow bar
- 6.8 Screw Driver set
- 6.9 Hammers
- 6.10 Petroleum Jelly
- 6.11 Torque Wrench
- 6.12 Insulation Tapes
- 6.13 Megger (Hand driven / Motorized) with test certificate
- 6.14 Hardware (Nuts/Bolts)
- 6.15 Metal free Non-woven cleaning clothes.

## 7.0 Installation Procedure and Methodology

### 7.1 Preparation Work

Before the commencement of installation for Lightning arrestor/ Lightning protection system the following are required to be carried out.  
(Installation of Lightning Arrestor should be carried out as per approved drawings and Manufacturer installation manual guidelines)

7.1.1 Check the route from stores to installation location is free for easy movement of the consignment.

7.1.2 Foundation area where the equipment to be shifted should be leveled, cleaned & temporary based required to rest the equipment.





**WORK METHOD STATEMENT –  
INSTALLATION OF LIGHTNING  
ARRESTOR**



- 7.1.3 Ensure no damage during unpacking of L.A.
- 7.1.4 Check the structures on which the lightning arrester is to be mounted is properly tightened and aligned and approval is obtained from Consultant, client for equipment installation. Check for Installation Checklist of equipment installation.
- 7.1.5 Ensure the capacity of mobile crane / tower crane, lifting tools, etc.
- 7.1.6 Checkout and ensure the tools & tackles required are sufficient at site.
- 7.1.7 Proper scaffolding for the technician going to align the equipment with support.
- 7.1.8 Unpack the Lightning arrester and ensure that the debris / packing materials are disposed from site to prescribed location.
- 7.1.9 While taking out of the cases too, arrester units should be placed in a right position as per the approved drawing. As L.A. is assembled in controlled condition, no attempt should be made at site to open or repair the arrester without consultation of manufacturer. Lifting / handling shall be done with only tested Nylon Belts / Nylon ropes.
- 7.1.10 When lifting a L.A. by the lugs and shackles provided for the purpose care shall be taken that simultaneous use should be made of all lugs / shackles in order to avoid any unbalance while lifting.
- 7.1.11 Care shall be taken such that the lifting chains / slings should not interfere or rub harshly with any part of L.A. to avoid damage.
- 7.1.12 The name plate shall be checked against equipment data sheet to confirm conformity with approved drawings / documents.
- 7.1.13 Ensure the L.A. support structure size and height is as per approved drawings.
- 7.1.14 Ensure the physical condition of the equipment.
- 7.1.15 Availability of all relevant documents i.e. – Approved drawings, material submittals, working procedure, Factory test report, check list, etc.

## 7.2 Installation Procedure

- 7.2.1 Shifting the equipment (i.e. Lightning Arrester, Down conductor, Elevation Pole) near to the installation location/ area by hydraulic mobile crane.
- 7.2.2 Removing the pack of the equipment to be installed & ensure that the debris / packing



**STRABAG****WORK METHOD STATEMENT –  
INSTALLATION OF LIGHTNING  
ARRESTOR****एम एम आर डी ए  
MMRDA**

materials are disposed from site to prescribed location.

- 7.2.3 Ensure the physical condition of the equipment (i.e. Lightning Arrestor, Down conductor, Elevation Pole)
- 7.2.4 Slowly lifting the equipment with the due permission of the supervisor who has implemented to handle the job.
- 7.2.5 Lifting up the elevation pole and placing on the base plate of the support structure. Fix the elevation pole onto structure supports using brackets and tighten with the nut-bolts properly
- 7.2.6 The technician will stand on the Scaffolding/ Hydraulic crane with safety belt to align the equipment with support.
- 7.2.7 The tip of the elevation pole should be positioned at least 2 meters (or as per approved drawing) above the structures to be protected.



- 7.2.8 Fix the Lightning Arrestor at the tip of elevation pole using brackets and tighten properly.
- 7.2.9 Make alignment of elevation pole & Lightning arrestor before releasing the hydraulic crane.
- 7.2.10 Tighten the down conductor at Lightning Arrestor end and fix onto support structure.
- 7.2.11 Install & fix the down conductor from Lightning Arrestor end upto earth pit at ground level.
- 7.2.12 Use insulator supports for fixing down conductor onto elevation pole and along the structure.





**STRABAG****WORK METHOD STATEMENT –  
INSTALLATION OF LIGHTNING  
ARRESTOR****एम एम आर डी ए  
MMRDA**

7.2.13 As per approved drawing structure support to be provided for L.A. counter installation.

7.2.14 The counter shall be on one side for all L.A. and shall be readable by proper approach.

7.2.15 Connection to be done as per approved drawing / manufacturer drawing from L.A. to Surge counter.



7.2.16 Earthing shall be carried out as per drawings and standard practices.

7.2.17 Complete Installation check list and offer for inspection after completion of installation





**WORK METHOD STATEMENT –  
INSTALLATION OF LIGHTNING  
ARRESTOR**



**8.0 Design & Drawings**

Manufacturers Catalogues and Final approved layout drawings.

**9.0 Quality**

Procedures described in the Method Statement (MS) for Installation of lighting protection system shall be followed and use following related Quality Formats;

- Inspection Testing Plan (ITP)
- Installation Checklist (ICL)
- Commissioning Checklist (CCL)

**10.0 Distribution**

Distribution of documents shall be as per contractual Specification and agreed protocols

\*\*\*\*\*



**STRABAG**

METHOD STATEMENT –  
BUILDING MANAGEMENT  
SYSTEM (BMS) & SCADA



एम एम आर डी ए  
MMRDA

## MUMBAI TRANS HARBOUR LINK PROJECT (MTHL)

**IFB No.: MMRDA/ENG1/0002561:**

Document No.	Document Name		Document Revision
0012	METHOD STATEMENT – BUILDING MANAGEMENT SYSTEM (BMS) & SCADA		R00
	Prepared By	Checked By	Approved By
Name	Sandeep	Mubashshir	Anuj
Designation	Manager	DGM	GM
Date	29.11.2021	29.11.2021	29.11.2021





**METHOD STATEMENT –  
BUILDING MANAGEMENT  
SYSTEM (BMS) & SCADA**



### 1.0 Purpose

The purpose of generating this method statement is to define the procedure step by step to implement the correct practices for Installation, Testing & Commissioning of Building Management System and SCADA to address the occupants of the building, control and monitoring of the system whenever it is necessary

### 2.0 Scope

This method statement refers to various work procedures contained within Strabag and Design / Drawing / Contractual specifications / Customer Quality Requirements which explains and covers Installation, Testing & Commissioning of Building Management System.

### 3.0 Reference

- 3.1 Project Plan
- 3.2 Contract Technical Specifications & Schematic Drawings
- 3.3 Approved Technical Data Sheets & IO Lists
- 3.4 Design Intent Drawings & Approved Shop Drawings
- 3.5 Manufacturers Catalogues & Recommendations

### 4.0 Abbreviations:

Project: MTHL  
Client: MMRDA  
Contractor: **STRABAG**  
MS – Method Statement  
FQP – Field Quality Plan  
ICL – Installation Check List  
CCL – Commissioning Check list  
MHS – Material Handling System Checklist  
MQAP – Manufacturer Quality Assurance Plan

### 5.0 Responsibilities

#### 5.1 Project Manager (Site In-charge):

- a) Ensure all required submittals area made and required plant, tools, material manpower is available in timely manner.
- b) Ensure all execution of works area carried out according to approvals, contract specifications, and approved shop drawings, MS, FQP, ICL and CCL.
- c) Ensure necessary coordination with all involved for timely completion of job.
- d) Will attend all site review and progress review meeting time to time.
- e) Overall responsibility of the site.





**METHOD STATEMENT –  
BUILDING MANAGEMENT  
SYSTEM (BMS) & SCADA**



**5.2 Site Engineer:**

- a) Timely provision of relevant and complete information, approved documents and instructions to site execution / installation team.
- b) Proper execution of works as per approved documents, MS, Drawings.
- c) The implementation of the procedures mentioned in MS with the help of concerned site engineer/ site supervisors.
- d) To carry out site work activities with regards to quality and safety requirements coordinating with site quality and safety representatives.

**5.3 Site Quality Engineer:**

- a) Identified Site Quality Engineer is responsible for preparation of project specific quality documents in consultation and support from regional quality representative.
- b) Responsible for communicating with all site staff about Quality requirements and responsible for reviewing all related documents.
- c) Responsible for conducting Tool Box talk meeting along with Site Incharge & Site Engineers for training to site technicians staff
- d) Responsible for incoming material inspection & accordingly raising MIR (Material Inspection Request) for PMC/ Client inspection
- e) Responsible for daily site audits and recording of observation with photographs
- f) Responsible for installation inspection and verification of Installation checklists filled by Site supervisors
- g) Raising the SIR (Site Inspection Request) for PMC/ Client inspection
- h) Responsible for corrective actions in coordination with Project Manager & Site Engineer and close the non-conformity identified during quality audits

**6.0 Tools/ Equipments/ Instruments used during site execution**

- 6.1 Scaffolding
- 6.2 Ladders
- 6.3 Electrical & Fitter Tool box
- 6.4 Spanners / Hand tools
- 6.5 Screw Driver set
- 6.6 Insulation tape
- 6.7 Continuity Tester





**METHOD STATEMENT –  
BUILDING MANAGEMENT  
SYSTEM (BMS) & SCADA**



**6.8 Multi-meter**

**7.0 Installation Procedure and Methodology**

**7.1 Preparation Work**

Before the commencement of installation, the following are required to be carried out:

- 7.1.1 Check for availability of Civil Clearance for Conduit, Cable laying, Cable tray and Panel installation.
- 7.1.2 Scaffolding, Ladders shall be arranged.
- 7.1.3 Check work area is clean and safe.
- 7.1.4 Ensure received panels and accessories are as per the drawings/BOQ and Specifications.
- 7.1.5 Ensure for material damages/short supply as per drawing/BOQ before installation.
- 7.1.6 Check for approved I/O List and Cable schedule available.
- 7.1.7 Check for approved Cable tray and Conduit layout available.
- 7.1.8 Check for approved System Architecture available.

**7.2 Installation**

This procedure is applicable for Installation, Testing & Commissioning of Building Management System that includes Integration & Automation of HVAC System, Control & Monitoring of Pumps and Monitoring of Electrical parameters through MODBUS Software Integration.

- 7.2.1 Mark the route for Conduiting, Cable tray installation as per approved shop drawing.
- 7.2.2 Conduiting and Cable tray work with fixing of clamps & supports shall be completed as per approved shop drawing.
- 7.2.3 Check for availability of civil clearance and space for mechanical mounting arrangement of all field Devices/Equipments like various Switches, Sensors and Transmitters etc.
- 7.2.4 Install all field devices/equipments at locations marked on shop drawing and as per manufacturers recommendations.
- 7.2.5 Install BMS Panels and ensure proper fixing as per drawing/layout.
- 7.2.6 Install all DDC controllers in BMS panel at location marked on drawing/layout.
- 7.2.7 Install the cables from DDC controller to the individual field equipments, devices as per shop drawing/cable schedule.





**METHOD STATEMENT –  
BUILDING MANAGEMENT  
SYSTEM (BMS) & SCADA**



- 7.2.8 Terminate the Power & Communication cables for BMS panel and DDC controllers Upto the field Equipments/Devices as per drawing/layout.
- 7.2.9 All Cables shall be terminated with lugs and ferrules. Also, provide cable identification tags as per approved drawing.
- 7.2.10 Earthing shall be connected and fixed to the BMS panel and DDC controllers as per drawing/layout.

### 7.3 Testing & Commissioning

- 7.3.1 Connect and check availability of Power supply to all controllers and Field Devices.
- 7.3.2 Check for Installation of Operating System & BMS Software in Central Computer.
- 7.3.3 Check for DDC Controller Communication with Master Controller.
- 7.3.4 Check for functioning of all field deceives and communication with DDC controllers, BMS Panel.
- 7.3.5 Check for functioning of all the parameters of field devices and displayed on central computer.

**Following documents/records shall be maintained after Testing & Commissioning:**

1. Check List for Installation, Testing & Commissioning
2. Operation & Maintenance manual
3. System write up should be attached
4. Periodical maintenance checks shall be attached
5. All the equipment manuals and spare parts (if applicable) shall be attached

### 8.0 Design & Drawings

Manufacturers Catalogues and Final approved layout drawings.

### 9.0 Quality

Procedures described in the Method Statement (MS) for Building Management System Installation, Testing and Commissioning shall be followed and use following Quality Formats:

- Inspection Test Plan (ITP)
- Installation, testing and Commissioning Checklist (ICL)

### 10.0 Distribution

Distribution of documents shall be as per Contractual Specification and agreed protocols.



**STRABAG**METHOD STATEMENT – FIRE  
ALARM SYSTEM (FAS)

**एम एम आर डी ए**  
MMRDA
**MUMBAI TRANS HARBOUR LINK PROJECT (MTHL)****IFB No.: MMRDA/ENG1/0002561:**

Document No.	Document Name		Document Revision
0013	METHOD STATEMENT – FIRE ALARM SYSTEM (FAS)		R00
	Prepared By	Checked By	Approved By
Name	Sandeep	Mubashshir	Anuj
Designation	Manager	DGM	GM
Date	29.11.2021	29.11.2021	29.11.2021







**METHOD STATEMENT – FIRE  
ALARM SYSTEM (FAS)**



### 1.0 Purpose

The purpose of generating this method statement is to define the procedure step by step to implement the correct practices for Installation, Testing & Commissioning of FIRE ALARM SYSTEM (FAS).

### 2.0 Scope

This method statement refers to various work procedures contained within Strabag and Design / Drawing / Contractual specifications / Customer Quality Requirements which explains covers Installation, Testing & Commissioning of FIRE ALARM SYSTEM (FAS).

### 3.0 Reference

- 3.1 Project Plan
- 3.2 Contract Technical Specifications & Schematic Drawings
- 3.3 Approved Technical Data Sheets
- 3.4 Design Intent Drawings & Approved Shop Drawings
- 3.5 Manufacturers Catalogues & Recommendations

### 4.0 Abbreviations:

Project: MTHL  
 Client: MMRDA  
 Contractor: **STRABAG**  
 MS – Method Statement  
 FQP – Field Quality Plan  
 ICL – Installation Check List  
 CCL – Commissioning Check list  
 MHS – Material Handling System Checklist  
 MQAP – Manufacturer Quality Assurance Plan

### 5.0 Responsibilities

#### 5.1 Project Manager (Site In-charge):

- a) Ensure all required submittals area made and required plant, tools, material manpower is available in timely manner.
- b) Ensure all execution of works area carried out according to approvals, contract specifications, and approved shop drawings, MS, FQP, ICL and CCL.
- c) Ensure necessary coordination with all involved for timely completion of job.
- d) Will attend all site review and progress review meeting time to time.
- e) Overall responsibility of the site.





**METHOD STATEMENT – FIRE  
ALARM SYSTEM (FAS)**



**5.2 Site Engineer:**

- Timely provision of relevant and complete information, approved documents and instructions to site execution / installation team.
- Proper execution of works as per approved documents, MS, Drawings.
- The implementation of the procedures mentioned in MS with the help of concerned site engineer/ site supervisors.
- To carry out site work activities with regards to quality and safety requirements coordinating with site quality and safety representatives.

**5.3 Site Quality Engineer:**

- Identified Site Quality Engineer is responsible for preparation of project specific quality documents in consultation and support from regional quality representative.
- Responsible for communicating with all site staff about Quality requirements and responsible for reviewing all related documents.
- Responsible for conducting Tool Box talk meeting along with Site Incharge & Site Engineers for training to site technicians staff
- Responsible for incoming material inspection & accordingly raising MIR (Material Inspection Request) for PMC/ Client inspection
- Responsible for daily site audits and recording of observation with photographs
- Responsible for installation inspection and verification of Installation checklists filled by Site supervisors
- Raising the SIR (Site Inspection Request) for PMC/ Client inspection
- Responsible for corrective actions in coordination with Project Manager & Site Engineer and close the non-conformity identified during quality audits

**6.0 Tools/ Equipments/ Instruments used during site execution**

- Scaffolding, Scissor Lift
- Ladders
- Electrical & Fitter Tool box
- Spanners / Hand tools
- Screw Driver set
- Insulation tape
- Continuity Tester
- Multi-meter





**METHOD STATEMENT – FIRE  
ALARM SYSTEM (FAS)**



## 7.0 Installation Procedure and Methodology

### 7.1 Preparation Work

Before the commencement of installation following are required to be carried out:

- 7.1.1 Check for availability of Civil Clearance for Conduit, Cable laying, Cable tray and Camera installation.
- 7.1.2 Scaffolding, Scissor Lift, Ladder shall be arranged. 7.1.3 Check work area is clean and safe.
- 7.1.4 Ensure received System, Cameras and accessories are as per the drawings/BOQ and Specifications.
- 7.1.5 Ensure for any damages/short supply as per drawing/BOQ before installation.

### 7.2 Installation

This procedure is applicable for Installation, Testing & Commissioning of Fire alarm system which comprises of Smoke detectors (Fire Sensor or Multi-sensor), Manual call points, Control modules, Monitor modules, Hooters.

- 7.2.1 Mark the route for conduiting, cable laying installation as per approved shop drawing.
- 7.2.2 Conduiting and Cable laying work with fixing of clamps shall be completed as per approved shop drawing and check for cable loop continuity.
- 7.2.3 Install the junction boxes as per distance and location marked on approved shop drawing.
- 7.2.4 Terminate the cables at junction boxes with proper glanding. Avoid making of extra knock out entry holes at the junction boxes.
- 7.2.5 If, Junction box found with extra knock entries open shall be covered/ sealed with Rubber bedding/ grommets.
- 7.2.6 Install the Detector base on junction boxes as per drawing and manufacturer recommendations.
- 7.2.7 Install the Various Detectors, Modules and terminate the cables as per drawing and manufacturer recommendations.
- 7.2.8 Install the Manual call points, Hooters at level and location as per drawing and manufacturer recommendations.
- 7.2.9 Install the Fire Alarm Panels with wiring arrangements as per drawing.
- 7.2.10 Terminate the Cables to the Fire alarm panels as per drawing.
- 7.2.11 All Cables shall be terminated with jugs and ferrules. Also, provide cable identification



**METHOD STATEMENT – FIRE  
ALARM SYSTEM (FAS)**



tags as per approved drawing.

7.2.12 Earthing shall be connected and fixed to the Fire alarm panel as per drawing.

### 7.3 Testing & Commissioning

- 7.3.1. Check for Cable loop continuity of detectors and other field devices in respective loops/zones.
- 7.3.2. Check for availability of UPS power supply voltage for Fire Alarm Panel.
- 7.3.3. Check for the approved FAS logic matrix.
- 7.3.4. Check for the functioning of detectors, modules and MCP's in all loops/zones.
- 7.3.5. Check for the functionality of Hooters in all loops/zones.
- 7.3.6. Check for appropriate Display / Message in the Fire Alarm Panel in case of alarm.
- 7.3.7. Check for Integration of Third Party Systems with the Fire Alarm System (if any)

**Following documents/records shall be maintained after Testing & Commissioning:**

1. Check List for Installation, Testing & Commissioning
2. Operation & Maintenance manual
3. System write up should be attached.
4. Periodical maintenance checks shall be attached
5. All the equipment manuals and spare parts (if applicable) shall be attached

### 8.0 Design & Drawings

Manufacturers Catalogues and Final approved layout drawings.

### 9.0 Quality

Procedures described in the Method Statement (MS) for FIRE ALARM SYSTEM (FAS) Installation, Testing and Commissioning shall be followed and use following Quality Formats:

- Inspection Test Plan (ITP)
- Installation, testing and Commissioning Checklist (ICL)

### 10.0 Distribution

Distribution of documents shall be as per contractual Specification and agreed protocols.



**STRABAG**METHOD STATEMENT – CCTV  
SYSTEM**MUMBAI TRANS HARBOUR LINK PROJECT (MTHL)****IFB No.: MMRDA/ENG1/0002561:**

Document No.	Document Name		Document Revision
0014	METHOD STATEMENT – CCTV SYSTEM		R00
	Prepared By	Checked By	Approved By
Name	Sandeep	Mubashshir	Anuj
Designation	Manager	DGM	GM
Date	29.11.2021	29.11.2021	29.11.2021





## METHOD STATEMENT – CCTV SYSTEM



### 1.0 Purpose

The purpose of generating this method statement is to define the procedure step by step to implement the correct practices for Installation, Testing & Commissioning of CCTV System.

### 2.0 Scope

This method statement refers to various work procedures contained within Strabag and Design / Drawing / Contractual specifications / Customer Quality Requirements which explains and covers Installation, Testing & Commissioning of CCTV System.

### 3.0 Reference

- 3.1 Project Plan
- 3.2 Contract Technical Specifications & Schematic Drawings
- 3.3 Approved Technical Data Sheets
- 3.4 Design Intent Drawings & Approved Shop Drawings
- 3.5 Manufacturers Catalogues & Recommendations

### 4.0 Abbreviations:

Project: MTHL  
 Client: MMRDA  
 Contractor: **STRABAG**  
 MS – Method Statement  
 FQP – Field Quality Plan  
 ICL – Installation Check List  
 CCL – Commissioning Check list  
 MHS – Material Handling System Checklist  
 MQAP – Manufacturer Quality Assurance Plan

### 5.0 Responsibilities

#### 5.1 Project Manager (Site In-charge):

- a) Ensure all required submittals area made and required plant, tools, material manpower is available in timely manner.
- b) Ensure all execution of works area carried out according to approvals, contract specifications, and approved shop drawings, MS, FQP, ICL and CCL.
- c) Ensure necessary coordination with all involved for timely completion of job.
- d) Will attend all site review and progress review meeting time to time.
- e) Overall responsibility of the site.

#### 5.2 Site Engineer:

- a) Timely provision of relevant and complete information, approved documents and





**METHOD STATEMENT – CCTV  
SYSTEM**



instructions to site execution / installation team.

- b) Proper execution of works as per approved documents, MS, Drawings.
- c) The implementation of the procedures mentioned in MS with the help of concerned site engineer/ site supervisors.
- d) To carry out site work activities with regards to quality and safety requirements coordinating with site quality and safety representatives.

**5.3 Site Quality Engineer:**

- a) Identified Site Quality Engineer is responsible for preparation of project specific quality documents in consultation and support from regional quality representative.
- b) Responsible for communicating with all site staff about Quality requirements and responsible for reviewing all related documents.
- c) Responsible for conducting Tool Box talk meeting along with Site Incharge & Site Engineers for training to site technicians staff
- d) Responsible for incoming material inspection & accordingly raising MIR (Material Inspection Request) for PMC/ Client inspection
- e) Responsible for daily site audits and recording of observation with photographs
- f) Responsible for installation inspection and verification of Installation checklists filled by Site supervisors
- g) Raising the SIR (Site Inspection Request) for PMC/ Client inspection
- h) Responsible for corrective actions in coordination with Project Manager & Site Engineer and close the non-conformity identified during quality audits

**6.0 Tools/ Equipments/ Instruments used during site execution**

- 6.1 Scaffolding, Scissor Lift
- 6.2 Ladders
- 6.3 Electrical & Fitter Tool box
- 6.4 Spanners / Hand tools
- 6.5 Screw Driver set
- 6.6 Insulation tape
- 6.7 Continuity Tester
- 6.8 Multi-meter





**METHOD STATEMENT – CCTV  
SYSTEM**



**एम एम आर डी ए  
MMRDA**

## 7.0 Installation Procedure and Methodology

### 7.1 Preparation Work

Before the commencement of installation following are required to be carried out:

- 7.1.1 Check for availability of Civil Clearance for Conduit, Cable laying, Cable tray and Camera installation.
- 7.1.2 Scaffolding, Scissor Lift, Ladder shall be arranged.
- 7.1.3 Check work area is clean and safe.
- 7.1.4 Ensure received System, Cameras and accessories are as per the drawings/BOQ and Specifications.
- 7.1.5 Ensure for any damages/short supply as per drawing/BOQ before installation.

### 7.2 Installation

This procedure is applicable for Installation, Testing & Commissioning of CCTV System which includes Cameras, Recorder and accessories as per system design.

- 7.2.1 Mark the route for Conduiting, Cable tray installation as per approved shop drawing
- 7.2.2 Conduiting and Cable tray work with fixing of clamps & supports shall be completed as per approved shop drawing.
- 7.2.3 Check for availability of civil clearance for installation of Cameras, Central recording System devices as per shop drawing.
- 7.2.4 Install the Cameras, Recorders at locations marked on approved shop drawing and as per manufacturers recommendations.
- 7.2.5 Complete the cable laying works as per approved drawing and cable schedule and check for cable loop continuity.
- 7.2.6 Terminate the camera cables through connector and identify cables with tags as per approved drawing and manufacturer guidelines.
- 7.2.7 Install the PTZ cameras with housing as per approved drawings.
- 7.2.8 Terminate the control cables for PTZ cameras and identify with tags as per approved drawing and manufacturer guidelines.
- 7.2.9 All Cables shall be terminated with lugs and ferrules. Also, provide cable identification tags as per approved drawing.
- 7.2.10 Earthing of Cameras, Recording System shall be connected & fixed as per drawing/layout.







**METHOD STATEMENT – CCTV  
SYSTEM**



### 7.3 Testing & Commissioning

- 7.3.1 Check for availability of UPS power supply voltage for Cameras, Recorders and other field devices.
- 7.3.2 Check for availability of Power supply voltages at individual cameras as per specifications.
- 7.3.3 Check that Cameras powered through fuses in series as per drawing.
- 7.3.4 Check for availability of Central system power supply voltage as per specifications.
- 7.3.5 Check that IP address available or collected from client for NVR, Cameras, Switches - If it's IP system.
- 7.3.6 Check that all Power points and LAN points working properly.
- 7.3.7 Check that all configuration details of Central system available with site engineer.
- 7.3.8 Check that all the devices are accessible for servicing and maintained.

**Following documents/records shall be maintained after Testing & Commissioning:**

1. Check List for Installation, Testing & Commissioning
2. Operation & Maintenance manual
3. System write up should be attached.
4. Periodical maintenance checks shall be attached
5. All the equipment manuals and spare parts (if applicable) shall be attached

### 8.0 Design & Drawings

Manufacturers Catalogues and Final approved layout drawings.

### 9.0 Quality

Procedures described in the Method Statement (MS) for CCTV System Installation, Testing and Commissioning shall be followed and use following Quality Formats:

- Inspection Test Plan (ITP)
- Installation, testing and Commissioning Checklist (ICL)

### 10.0 Distribution

Distribution of documents shall be as per contractual Specification and agreed protocols.

\*\*\*\*\*



5 | 5

2134

**STRABAG**METHOD STATEMENT – PUBLIC  
ADDRESS SYSTEM (P.A.)

**एम एम आर डी ए  
MMRDA**
**MUMBAI TRANS HARBOUR LINK PROJECT (MTHL)****IFB No.: MMRDA/ENG1/0002561:**

Document No.	Document Name		Document Revision
0015	METHOD STATEMENT – PUBLIC ADDRESS SYSTEM (P.A.)		R00
	Prepared By	Checked By	Approved By
Name	Sandeep	Mubashshir	Anuj
Designation	Manager	DGM	GM
Date	29.11.2021	29.11.2021	29.11.2021



**STRABAG****METHOD STATEMENT – PUBLIC  
ADDRESS SYSTEM (P.A.)****एम एम आर डी ए  
MMRDA****1.0 Purpose**

The purpose of generating this method statement is to define the procedure step by step to implement the correct practices for Installation, Testing & Commissioning of PUBLIC ADDRESS SYSTEM (P.A.).

**2.0 Scope**

This method statement refers to various work procedures contained within Strabag and Design / Drawing / Contractual specifications / Customer Quality Requirements which explains and covers Installation, Testing & Commissioning of PUBLIC ADDRESS SYSTEM (P.A.).

**3.0 Reference**

- 3.1 Project Plan
- 3.2 Contract Technical Specifications & Schematic Drawings
- 3.3 Approved Technical Data Sheets
- 3.4 Design Intent Drawings & Approved Shop Drawings
- 3.5 Manufacturers Catalogues & Recommendations

**4.0 Abbreviations:**

Project: MTHL  
 Client: MMRDA  
 Contractor: **STRABAG**  
 MS – Method Statement  
 FQP – Field Quality Plan  
 ICL – Installation Check List  
 CCL – Commissioning Check list  
 MHS – Material Handling System Checklist  
 MQAP – Manufacturer Quality Assurance Plan

**5.0 Responsibilities****5.1 Project Manager (Site In-charge):**

- a) Ensure all required submittals area made and required plant, tools, material manpower is available in timely manner.
- b) Ensure all execution of works area carried out according to approvals, contract specifications, and approved shop drawings, MS, FQP, ICL and CCL.
- c) Ensure necessary coordination with all involved for timely completion of job.
- d) Will attend all site review and progress review meeting time to time.
- e) Overall responsibility of the site.

**5.2 Site Engineer:**

- a) Timely provision of relevant and complete information, approved documents and





**METHOD STATEMENT – PUBLIC  
ADDRESS SYSTEM (P.A.)**



instructions to site execution / installation team.

- b) Proper execution of works as per approved documents, MS, Drawings.
- c) The implementation of the procedures mentioned in MS with the help of concerned site engineer/ site supervisors.
- d) To carry out site work activities with regards to quality and safety requirements coordinating with site quality and safety representatives.

**5.3 Site Quality Engineer:**

- a) Identified Site Quality Engineer is responsible for preparation of project specific quality documents in consultation and support from regional quality representative.
- b) Responsible for communicating with all site staff about Quality requirements and responsible for reviewing all related documents.
- c) Responsible for conducting Tool Box talk meeting along with Site Incharge & Site Engineers for training to site technicians staff
- d) Responsible for incoming material inspection & accordingly raising MIR (Material Inspection Request) for PMC/ Client inspection
- e) Responsible for daily site audits and recording of observation with photographs
- f) Responsible for installation inspection and verification of Installation checklists filled by Site supervisors
- g) Raising the SIR (Site Inspection Request) for PMC/ Client inspection
- h) Responsible for corrective actions in coordination with Project Manager & Site Engineer and close the non-conformity identified during quality audits

**6.0 Tools/ Equipments/ Instruments used during site execution**

- 6.1 Scaffolding, Scissor Lift
- 6.2 Ladders
- 6.3 Electrical & Fitter Tool box
- 6.4 Spanners / Hand tools
- 6.5 Screw Driver set
- 6.6 Insulation tape
- 6.7 Continuity Tester
- 6.8 Multi-meter





METHOD STATEMENT – PUBLIC  
ADDRESS SYSTEM (P.A.)



## 7.0 Installation Procedure and Methodology

### 7.1 Preparation Work

Before the commencement of installation following are required to be carried out:

- 7.1.1 Check for availability of Civil Clearance for Conduit, Cable laying, Cable tray and Camera installation.
- 7.1.2 Scaffolding, Scissor Lift, Ladder shall be arranged.
- 7.1.3 Check work area is clean and safe.
- 7.1.4 Ensure received System, Cameras and accessories are as per the drawings/BOQ and Specifications.
- 7.1.5 Ensure for any damages/short supply as per drawing/BOQ before installation.

### 7.2 Installation

This procedure is applicable for Installation, Testing & Commissioning of CCTV System which includes Cameras, Recorder and accessories as per system design.

- 7.2.1 Mark the route for Conduiting, Cable tray installation as per approved shop drawing
- 7.2.2 Conduiting and Cable tray work with fixing of clamps & supports shall be completed as per approved shop drawing.
- 7.2.3 Check for availability of civil clearance for installation of Cameras, Central recording System devices as per shop drawing.
- 7.2.4 Install the Cameras, Recorders at locations marked on approved shop drawing and as per manufacturers recommendations.
- 7.2.5 Complete the cable laying works as per approved drawing and cable schedule and check for cable loop continuity.
- 7.2.6 Terminate the camera cables through connector and identify cables with tags as per approved drawing and manufacturer guidelines.
- 7.2.7 Install the PTZ cameras with housing as per approved drawings.
- 7.2.8 Terminate the control cables for PTZ cameras and identify with tags as per approved drawing and manufacturer guidelines.
- 7.2.9 All Cables shall be terminated with lugs and ferrules. Also, provide cable identification tags as per approved drawing.
- 7.2.10 Earthing of Cameras, Recording System shall be connected & fixed as per drawing/layout.





**METHOD STATEMENT – PUBLIC  
ADDRESS SYSTEM (P.A.)**



### 7.3 Testing & Commissioning

- 7.3.1 Check for availability of UPS power supply voltage for Cameras, Recorders and other field devices.
- 7.3.2 Check for availability of Power supply voltages at individual cameras as per specifications.
- 7.3.3 Check that Cameras powered through fuses in series as per drawing.
- 7.3.4 Check for availability of Central system power supply voltage as per specifications.
- 7.3.5 Check that IP address available or collected from client for NVR, Cameras, Switches - If it's IP system.
- 7.3.6 Check that all Power points and LAN points working properly.
- 7.3.7 Check that all configuration details of Central system available with site engineer.
- 7.3.8 Check that all the devices are accessible for servicing and maintained.

**Following documents/records shall be maintained after Testing & Commissioning:**

1. Check List for Installation, Testing & Commissioning
2. Operation & Maintenance manual
3. System write up should be attached.
4. Periodical maintenance checks shall be attached
5. All the equipment manuals and spare parts (if applicable) shall be attached

### 8.0 Design & Drawings

Manufacturers Catalogues and Final approved layout drawings.

### 9.0 Quality

Procedures described in the Method Statement (MS) for PUBLIC ADDRESS SYSTEM (P.A.) Installation, Testing and Commissioning shall be followed and use following Quality Formats:

- Inspection Test Plan (ITP)
- Installation, testing and Commissioning Checklist (ICL)

### 10.0 Distribution

Distribution of documents shall be as per contractual Specification and agreed protocols.



**STRABAG**

METHOD STATEMENT –  
INSTALLATION OF HVAC  
EQUIPMENTS

**एम एम आर डी ए  
MMRDA**

**MUMBAI TRANS HARBOUR LINK PROJECT (MTHL)**

**IFB No.: MMRDA/ENG1/0002561:**

Document No.	Document Name		Document Revision
0016	METHOD STATEMENT – INSTALLATION OF HVAC EQUIPMENTS		R00
	<b>Prepared By</b>	<b>Checked By</b>	<b>Approved By</b>
<b>Name</b>	Sandeep	Mubashshir	Anuj
<b>Designation</b>	Manager	DGM	GM
<b>Date</b>	29.11.2021	29.11.2021	29.11.2021





**METHOD STATEMENT –  
INSTALLATION OF HVAC  
EQUIPMENTS**



### 1.0 Purpose

The purpose of this procedure is to detail the necessary criteria for installation work of Major Equipment like VRF/VENTILATION Fans as per approved shop drawings and manufacturer's recommendations, to produce a quality installation conforming to relative standards and project specifications.

### 2.0 Scope

This method statement refers to various work procedures contained within Strabag project quality plan and Contract specifications which explains and covers the Equipment installation work for HVAC System

### 3.0 Reference

- 3.1 Project Quality Plan
- 3.2 Health & Safety Plan
- 3.3 Contract Technical Specifications
- 3.4 Approved Technical Data Sheets
- 3.5 Design Intent Drawings & Approved Shop Drawings
- 3.6 Manufacturers Catalogues & Recommendations

### 4.0 Abbreviations:

Project: MTHL  
Client: MMRDA  
Contractor: **STRABAG**  
MS – Method Statement  
FQP – Field Quality Plan  
ICL – Installation Check List  
CCL – Commissioning Check list  
MHS – Material Handling System Checklist  
MQAP – Manufacturer Quality Assurance Plan







**METHOD STATEMENT –  
INSTALLATION OF HVAC  
EQUIPMENTS**



**5.0 Responsibilities**

**5.1 Project Manager (Site In-charge):**

- Ensure all required submittals area made and required plant, tools, material manpower is available in timely manner.
- Ensure all execution of works area carried out according to approvals, contract specifications, and approved shop drawings, MS, FQP, ICL and CCL.
- Ensure necessary coordination with all involved for timely completion of job.
- Will attend all site review and progress review meeting time to time.
- Overall responsibility of the site.

**5.2 Site Engineer:**

- Timely provision of relevant and complete information, approved documents and instructions to site execution / installation team.
- Proper execution of works as per approved documents, MS, Drawings.
- The implementation of the procedures mentioned in MS with the help of concerned site engineer/ site supervisors.
- To carry out site work activities with regards to quality and safety requirements coordinating with site quality and safety representatives.

**5.3 Site Quality Engineer:**

- Identified Site Quality Engineer is responsible for preparation of project specific quality documents in consultation and support from regional quality representative.
- Responsible for communicating with all site staff about Quality requirements and responsible for reviewing all related documents.
- Responsible for conducting Tool Box talk meeting along with Site Incharge & Site Engineers for training to site technicians staff
- Responsible for incoming material inspection & accordingly raising MIR (Material Inspection Request) for PMC/ Client inspection
- Responsible for daily site audits and recording of observation with photographs
- Responsible for installation inspection and verification of Installation checklists filled by Site supervisors
- Raising the SIR (Site Inspection Request) for PMC/ Client inspection
- Responsible for corrective actions in coordination with Project Manager & Site Engineer and close the non-conformity identified during quality audit.





**METHOD STATEMENT –  
INSTALLATION OF HVAC  
EQUIPMENTS**



**6.0 Tools/ Equipments/ Instruments used during site execution**

Plant and equipment required for this activity as per listed below.

- 6.1 Lifting & Shifting Equipment
- 6.2 General conventional equipment's for adjusting & fixing (spanner, hammer, screw driver, pipe wrench and sockets, etc.
- 6.3 Scaffolding, ladders, platform, etc.

**7.A Installation Procedure for VRF System:**

**General :**

Purpose of this is to outline the method of storage, handling, fabrication; installation of VRF System.

**Material:**

- a) VRF IDU/ODU As per approved material submittals
- b) Supports-as per approved schedule/typical fixing drawing. angles / channels, threaded rods, anchor fasteners, Nuts, Washers etc. as per approved drawings/schedule.
- c) Consumables: For processes like drill m/c etc.

**References**

- i. Manufacturer's catalogue for fittings, supports, etc.
- ii. Approved material submittal / Technical Data Sheets
- iii. Approved Shop drawings Issued for Construction

**Method:**

**Storage:**

- i. ODU/IDUs shall be stacked on a flat surface in safer area.
- ii. While stacking, Material it shall be ensured that material like coil ,copper header material placed on safe area to avoid damages.
- iii. Any items found damaged or not suitable as per project requirements shall be removed from site. If required, to store temporarily, they shall be clearly marked and stored separately to prevent any re-use





**METHOD STATEMENT –  
INSTALLATION OF HVAC  
EQUIPMENTS**



**Preparation:**

- 1) Check and ensure all drawings used for installation are latest and approved for construction.
- 2) Check the co-ordination ODU/IDU installation layout with other services.
- 3) Check and ensure sufficient clearance is available for ref net joints and valve stations.
- 4) Fabricate the structural supports from angles/channels as per support schedule mentioned in the drawings. Apply primer on the support and finally paint .
- 5) Check and ensure sufficient clearance is available around motor

**Installation:**

**Note:**

Prior to start installations one sample installation as per approved drawings and project specifications to be made and offered for Consultant / customer for inspections.

Check dimension of ODU base and mounting points.

1. Fix the support rods.
2. Size of hanger rods and type of vibration isolator shall be followed the summary table.
3. Hang or mount IDU with rubber pads or spring vibration isolator in accordance with Standard installation drawing.
4. Adjust IDU level to meet drain water flow to direction of condensate drain pipe. Fix bolts, nuts and washers.
5. In case of IDU to be installed in the conceal area, service panel shall be provided. Service panel location and its detail drawing shall be coordinated with architectural work in working drawing stage.

**Pressure Testing:**

The purpose of this outline method of pressure testing wherever applicable for piping. (Hydraulic, Pneumatic, Slope (drain/ refrigeration)).

**Material**

- a) For Hydraulic testing –Set of Hydraulic Test Pump.
- b) For Slope verification Testing- Water with appropriate apparatus
- c) Calibrated Pressure Gauges.



**STRABAG****METHOD STATEMENT –  
INSTALLATION OF HVAC  
EQUIPMENTS****एम एम आर डी ए  
MMRDA****7.B Installation of Ventilation Fans****General :**

Purpose of this is to outline the method of storage, handling, fabrication; installation of Ventilation Fans.

**Material:**

- Fan As per approved material submittals
- Supports: as per approved schedule/typical fixing drawing, Clevis hangers, U Strap / U Bolts, angles / channels, threaded rods, anchor fasteners, Nuts, Washers etc. as per approved drawings/schedule.

**References**

- Manufacturer's catalogue for fans, fittings, supports etc.
- Approved material submittal / Technical Data Sheets
- Approved Shop drawings Issued for Construction.

**Method:****Storage:**

- Fans shall be stacked on a flat surface with adequate supports.
- Any items found damaged or not suitable as per project requirements shall be removed from site. If required to store temporarily, they shall be clearly marked and stored separately to prevent any advertent use

**Preparation:**

- Check and ensure all drawings used for installation are latest and approved for construction.
- Check the co-ordination of fan layout with other services and reflected ceiling and decide fan.
- Check and ensure sufficient clearance is available around ducts, vcd's and fans.
- Fabricate the structural supports from angles/channels as per support schedule mentioned in the drawings. Apply primer on the support and finally paint the support as per approved colour enamel paint.

**Installation:**

- Axial Fan / Inline \_ Centrifugal/Inline Mix Flow Fan./Jet Fans/ etc





**METHOD STATEMENT –  
INSTALLATION OF HVAC  
EQUIPMENTS**



- Check Builders work and installation location
- Check equipment type and model
- Check fan components have no visible damage.
- Rotate fan blower by hand for abnormality check of blower and housing.
- Ensure that there is no foreign material inside blower and housing.
- Check dimension of fan base or mounting point.
- Install expansion bolts.
- Check air flow direction of fan.
- Mount the fan with vibration isolator on steel base or hanging support, Fix bolts, nuts and washer.
- Level the Fan.

## 2. Centrifugal Fan

- Check Builders work and installation location.
- Check equipment type and model.
- Check fan components have no visible damage.
- Rotate fan blower by hand for abnormality checked of blower and housing.
- Adjust tension of fan belts and pre \_ alignment.
- Ensure that there is no foreign material inside blower and housing.
- Set up belt guard (If required)
- Check dimension to fan base or mounting point.
- Install expansion bolts.
- Check air flow direction of fan
- Mount the fan with vibration isolator on steel base or hanging support, fix bolts, nuts, and washer.

## 8.0 Design & Drawings

Manufacturers Catalogues and Final approved layout drawings.

## 9.0 Quality

Procedures described in the Method Statement (MS) for HVAC Equipment shall be followed and use following Quality Formats:

- Inspection Test Plan (ITP)
- Method Statement (MS)
- Installation, testing and Commissioning Checklist (ICL)

## 10.0 Distribution

Distribution of documents shall be as per contractual Specification and agreed protocols.



**STRABAG**METHOD STATEMENT –  
INSTALLATION OF DUCTING

**एम एम आर डी ए**  
MMRDA
**MUMBAI TRANS HARBOUR LINK PROJECT (MTHL)****IFB No.: MMRDA/ENG1/0002561:**

Document No.	Document Name		Document Revision
0017	METHOD STATEMENT – INSTALLATION OF DUCTING		R00
	Prepared By	Checked By	Approved By
Name	Sandeep	Mubashshir	Anuj
Designation	Manager	DGM	GM
Date	29.11.2021	29.11.2021	29.11.2021

**1.0 Purpose**

Page 1 | 6



2147

**STRABAG****METHOD STATEMENT –  
INSTALLATION OF DUCTING****एम एम आर डी ए  
MMRDA**

The purpose of generating this method statement is to define the procedure step by step to implement the correct practices for Ducting work for HVAC System.

**2.0 Scope**

This method statement refers to various work procedures contained within Strabag project quality plan and Contract specifications which explains and covers the Ducting work for HVAC System.

**3.0 Reference**

- 3.1 Project Quality Plan
- 3.2 Health & Safety Plan
- 3.3 Contract Technical Specifications
- 3.4 Approved Technical Data Sheets
- 3.5 Design Intent Drawings & Approved Shop Drawings
- 3.6 Manufacturers Catalogues & Recommendations

**4.0 Abbreviations:**

Project: MTHL  
 Client: MMRDA  
 Contractor: **STRABAG**  
 MS – Method Statement  
 FQP – Field Quality Plan  
 ICL – Installation Check List  
 CCL – Commissioning Check list  
 MHS – Material Handling System Checklist  
 MQAP – Manufacturer Quality Assurance Plan

**5.0 Responsibilities****5.1 Project Manager (Site In-charge):**

- a) Ensure all required submittals area made and required plant, tools, material manpower is available in timely manner.
- b) Ensure all execution of works area carried out according to approvals, contract specifications, and approved shop drawings, MS, FQP, ICL and CCL.



**STRABAG****METHOD STATEMENT –  
INSTALLATION OF DUCTING****एम एम आर डी ए  
MMRDA**

- c) Ensure necessary coordination with all involved for timely completion of job.
- d) Will attend all site review and progress review meeting time to time.
- e) Overall responsibility of the site.

**5.2 Site Engineer:**

- a) Timely provision of relevant and complete information, approved documents and instructions to site execution / installation team.
- b) Proper execution of works as per approved documents, MS, Drawings.
- c) The implementation of the procedures mentioned in MS with the help of concerned site engineer/ site supervisors.
- d) To carry out site work activities with regards to quality and safety requirements coordinating with site quality and safety representatives.

**5.3 Site Quality Engineer:**

- a) Identified Site Quality Engineer is responsible for preparation of project specific quality documents in consultation and support from regional quality representative.
- b) Responsible for communicating with all site staff about Quality requirements and responsible for reviewing all related documents.
- c) Responsible for conducting Tool Box talk meeting along with Site Incharge & Site Engineers for training to site technicians staff
- d) Responsible for incoming material inspection & accordingly raising MIR (Material Inspection Request) for PMC/ Client inspection
- e) Responsible for daily site audits and recording of observation with photographs
- f) Responsible for installation inspection and verification of Installation checklists filled by Site supervisors
- g) Raising the SIR (Site Inspection Request) for PMC/ Client inspection
- h) Responsible for corrective actions in coordination with Project Manager & Site Engineer and close the non-conformity identified during quality audit.

**6.0 Tools/ Equipments/ Instruments used during site execution**

Plant and equipment required for this activity as per listed below.

- 6.1 Lifting & Shifting Equipment
- 6.2 Drilling machine, Wooden Hammer, Rivet M/C
- 6.3 Spanners, Hand Gloves
- 6.4 Scaffolding, ladders, platform, etc.

**7.0 Installation Procedure:****7.A. Ducting:**





**METHOD STATEMENT –  
INSTALLATION OF DUCTING**



Purpose of this is to outline the method of storage, handling, fabrication; installation of Ducting.

**Material:**

- a) Duct: TDF,C&S duct L Profile, etc., As per approved material submittals
- b) Supports: as per approved schedule/typical fixing drawing. Slotted angles / , threaded rods, anchor fasteners, Nuts, Washers etc. as per approved drawings/schedule.
- c) Consumables: For processes like sealant, Gasket etc.

**References**

- a) As per SMACNA Standards.
- b) Approved material submittal / Technical Data Sheets
- c) Approved Shop drawings Issued for Construction.

**Method:**

a) **Storage:**

- i) Ducts shall be stacked on a flat surface with adequate supports
- ii) While stacking, it shall be ensured that ducts of bigger sizes are placed below and smaller sizes are on top.
- iii) Any items found damaged or not suitable as per project requirements shall be removed from site. If required to store temporarily, they shall be clearly marked and stored separately to prevent any advertent use

b) **Preparation:**

- i) Check and ensure all drawings used for installation are latest and approved for construction.
- ii) Check the co-ordinated approved ducting layout with other services and reflected ceiling plan.
- iv) Check and ensure sufficient clearance is available around duct for insulation & dampers handle etc.
- v) Installed the supports as per support schedule mentioned in the drawings.



**STRABAG****METHOD STATEMENT –  
INSTALLATION OF DUCTING****Installation:****Note:**

Prior to start installations one sample installation as per approved drawings and project specifications to be made and offered for Consultant / customer for Inspections.

**Ducting:**

- I. Fabricate the folded ducts/ "L" Profile on the shop floor below, where the erection will take place.
- II. Fix the rubber gasket on the flange.
- III. Joint the ducts using crimping tool and by tightening the corner bolt nuts.
- IV. If any leakages in the ducts, Apply sealants on joints of the ducting.
- V. Ensure no discontinuities in the ducts by periodic manual & visual inspection.
- VI. Protect all equipment by means of protective covering prior to start of works.
- VII. Open duct to be covered by 1 layer of polythene.
- VIII. The duct location to be marked and support brackets to be installed.
- IX. Puf strip of 25 mm thick to be pasted between support and duct.
- X. Ensure that while erecting the ducts should not be damaged.
- XI. Supports for the ducts should be made according to the approved drawings.
- XII. Duct shall not be rest on false ceiling and shall be on level from bottom.
- XIII. Check the levels with respect to the reference level on the walls marked by other agencies.
- XIV. Cut the extra length of the threaded rod. (3 to 5 thread)
- XV. Install Volume control Damper / Fire Damper according to the approved shop drawings or where required.
- XVI. All ductwork installation should be checked and approved by the Client before insulation.
- XVII. All ducts up to 75cms width within conditioned spaces shall have slip nd drive (C & S/SS) joints. The internal ends of slip joints shall be either Pittsburgh or snap button as per SMACNA practice, to ensure air tightness.
- XVIII. Changes in dimensions and shape of ducts shall be gradual (between 1:4 and 1:7). Air turns (vanes) shall be installed in 400mm and above bends and duct collars designed to permit the air to make the turn without appreciable turbulence.
- XIX. Where ducts pass through brick or masonry openings, it shall be provided with 25mm thick TF quality expanded polystyrene around the duct and totally covered with fire barrier mortar / pop for complete sealing.
- XX. Self -Adhesive Neoprene rubber / or O.E.M. supplied lining 3 mm nominal thickness shall be used between duct flanges and between duct support on all ducting installation.
- XXI. Light test ( visual inspection) to be carried out to ensure minimization of leakages for main ducts before taking out the branches.



**STRABAG****METHOD STATEMENT –  
INSTALLATION OF DUCTING****एम एम आर डी ए  
MMRDA****8.0 Design & Drawings**

Manufacturers Catalogues and Final approved layout drawings.

**9.0 Quality**

Procedures described in the Method Statement (MS) for HVAC Ducting shall be followed and use following Quality Formats:

- Inspection Test Plan (ITP)
- Method Statement (MS)
- Installation, testing and Commissioning Checklist (ICL)

**10.0 Distribution**

Distribution of documents shall be as per contractual Specification and agreed protocols.

\*\*\*\*\*



**STRABAG**METHOD STATEMENT – FIRE  
FIGHTING EQUIPMENTS**MUMBAI TRANS HARBOUR LINK PROJECT (MTHL)****IFB No.: MMRDA/ENG1/0002561:**

Document No.	Document Name		Document Revision
0018	METHOD STATEMENT – FIRE FIGHTING EQUIPMENTS		R00
	<b>Prepared By</b>	<b>Checked By</b>	<b>Approved By</b>
<b>Name</b>	Sandeep	Mubashshir	Anuj
<b>Designation</b>	Manager	DGM	GM
<b>Date</b>	29.11.2021	29.11.2021	29.11.2021





## METHOD STATEMENT – FIRE FIGHTING EQUIPMENTS



### 1.0 Purpose

The purpose of this procedure is to detail the necessary criteria for installation work of Major Equipment like Pump/Tank as per approved shop drawings and manufacturer's recommendations, to produce a quality installation conforming to relative standards and project specifications

### 2.0 Scope

This method statement refers to various work procedures contained within Strabag project quality plan and Contract specifications which explains and covers the Pump/ Tank installation work for Fire Fighting System.

### 3.0 Reference

- 3.1 Project Quality Plan
- 3.2 Contract Technical Specifications
- 3.3 Approved Technical Data Sheets
- 3.4 Design Intent Drawings & Approved Shop Drawings
- 3.5 Manufacturers Catalogues & Recommendations

### 4.0 Abbreviations:

Project: MTHL  
 Client: MMRDA  
 Contractor: **STRABAG**  
 MS – Method Statement  
 FQP – Field Quality Plan  
 ICL – Installation Check List  
 CCL – Commissioning Check list  
 MHS – Material Handling System Checklist  
 MQAP – Manufacturer Quality Assurance Plan

### 5.0 Responsibilities

#### 5.1 Project Manager (Site In-charge):

- a) Ensure all required submittals area made and required plant, tools, material manpower is available in timely manner.
- b) Ensure all execution of works area carried out according to approvals, contract specifications, and approved shop drawings, MS, FQP, ICL and CCL.
- c) Ensure necessary coordination with all involved for timely completion of job.





## METHOD STATEMENT – FIRE FIGHTING EQUIPMENTS



- d) Will attend all site review and progress review meeting time to time.
- e) Overall responsibility of the site.

### 5.2 Site Engineer:

- a) Timely provision of relevant and complete information, approved documents and instructions to site execution / installation team.
- b) Proper execution of works as per approved documents, MS, Drawings.
- c) The implementation of the procedures mentioned in MS with the help of concerned site engineer/ site supervisors.
- d) To carry out site work activities with regards to quality and safety requirements coordinating with site quality and safety representatives.

### 5.3 Site Quality Engineer:

- a) Identified Site Quality Engineer is responsible for preparation of project specific quality documents in consultation and support from regional quality representative.
- b) Responsible for communicating with all site staff about Quality requirements and responsible for reviewing all related documents.
- c) Responsible for conducting Tool Box talk meeting along with Site Incharge & Site Engineers for training to site technicians staff
- d) Responsible for incoming material inspection & accordingly raising MIR (Material Inspection Request) for PMC/ Client inspection
- e) Responsible for daily site audits and recording of observation with photographs
- f) Responsible for installation inspection and verification of installation checklists filled by Site supervisors
- g) Raising the SIR (Site Inspection Request) for PMC/ Client inspection
- h) Responsible for corrective actions in coordination with Project Manager & Site Engineer and close the non-conformity identified during quality audits

### 6.0 Tools/ Equipments/ Instruments used during site execution

Plant and equipment required for this activity as per listed below.

#### 6.1 Lifting & Shifting Equipment

#### 6.2 General conventional equipment's for adjusting & fixing (spanner, hammer, screw driver, pipe wrench and sockets, etc.) Scaffolding, ladders, platform, Chain Block etc

### 7.0 Construction Method and Sequence of Work



**STRABAG****METHOD STATEMENT – FIRE  
FIGHTING EQUIPMENTS****7A. Installation Procedure for Pump****General :**

This method statement describes the installation of Fire Fighting Pump. Detail of the procedure contained herein may be modified based on the actual site condition.

**Material:**

- i. Chain pulley blocks
- ii. Wooden slippers
- iii. Hydraulic jacks
- iv. Solid pipes
- v. Wire rope

**References:**

- a) Manufacturer's catalogue for Pumps, fittings, supports, Inertia block
- b) Approved material submittal / Technical Data Sheets
- c) Approved Shop drawings issued for Construction.

**Method:****a) Storage:**

- i) Pumps shall be stacked on a flat surface with adequate supports.
- ii) Any items found damaged or not suitable as per project requirements shall be removed from site. If required to store temporarily, they shall be clearly marked and stored separately to prevent any adverse use.

**b) Preparation:**

- i. Check and ensure all drawings used for installation are latest and approved for construction.
- ii. Check the co-ordination pumps installation layout with other services.
- iii. Check and ensure sufficient clearance is available between two pumps and valve stations.
- iv. Fabricate the structural supports from angles/channels as per **support schedule** mentioned in the drawings. Supports shall be Hot deep Galvanize. Support for purpose installation of equipment shall be accordance with manufacturer recommendation

**c) Installation****Note:**

Prior to start installations one sample installation as per approved drawings and project specifications to be made and offered for Consultant / customer Inspections.

**1. Installation of Inertia Block and Spring Isolator:**

- 1.1 Check the dimensions of pump base and the mounting points



**STRABAG****METHOD STATEMENT – FIRE  
FIGHTING EQUIPMENTS****एम एम आर डी ए  
MMRDA**

- 1.2 Check size, height and mounting points to mount to pump base and to plinth of Inertia Block. shall be as per manufacturer recommendation, plinth if any scope to be clarify
  - 1.3 Prepare C-Channel for frame and reinforcing steel rod.
  - 1.4 Clean C-Channel and steel rod.
  - 1.5 Pour and cure concrete
  - 1.6 Check color code and operating height of Spring Isolators as per approved material submittal.
  - 1.7 Locate the Inertia Block on the plinth with temporary supports at proper height, install expansion bolts in the plinth.
  - 1.8 Install Spring Isolators at Inertia block base. Fix bolts, washers, nuts on Spring Isolators and expansion bolts.
  - 1.9 Remove temporary supports and level the Inertia Block by adjusting Spring Isolator.
  - 1.10 After installation, check visual appearance and mechanical security.
  - 1.11 Check the cleanness and freedom from obstruction.
  - 1.12 End installation shall be re verify or witness from manufacturer as joint inspection.
2. Installation of a Pump and Accessories:
    - 2.1 Check the dimensions of pump base and the mounting points.
    - 2.2 Check and install expansion bolts in the Inertia Block.
    - 2.3 Install the pump on the Inertia Block and fix bolts, washers, nuts on pump base.
    - 2.4 After installation, check visual appearance and mechanical security.
    - 2.5 Check the cleanness and freedom from obstruction.
    - 2.6 End installation shall be reverify or witness from manufacturer as joint inspection

**7B. Installation Procedure for General Equipment like Tank, etc.****General:**

This method statement describes the installation/construction of General Equipment like Tank, etc. Detail of the procedure contained herein may be modified based on the actual site condition.

**Material**

- a) Chain pulley blocks
- b) Wooden slippers
- c) hydraulic jacks
- d) Solid pipes
- e) Wire rope

**References**

- a) Manufacturer's catalogue for Pumps, fittings, supports, Inertia base. etc.
- b) Approved material submittal / Technical Data Sheets







**METHOD STATEMENT – FIRE  
FIGHTING EQUIPMENTS**



- c) Approved Shop drawings Issued for Construction.
- d) WPS/PQR.

**Method:**

a) **Storage:**

- i. Equipment shall be stacked on a flat surface with adequate supports.
- ii. Any items found damaged or not suitable as per project requirements shall be removed from site. If required to store temporarily, they shall be clearly marked and stored separately to prevent any advertent use.

b) **Preparation:**

- i) Check and ensure all drawings used for installation are latest and approved for construction.
- ii) Check the co-ordination pumps installation layout with other services.
- iii) Check and ensure sufficient clearance is available between two pumps and valve stations.
- iv) Fabricate the structural supports from angles/channels as per **support schedule** mentioned in the drawings.

c) **Installation**

**Note:** Prior to start installations one sample installation as per approved drawings and project specifications to be made and offered for Consultant / customer for Inspections.

1 Installation of Inertia Block and Spring Isolator. ( If applicable):

- i. Check the dimensions of pump base and the mounting points.
- ii. Check size, height and mounting points to mount to equipment base and to plinth of Inertia Block.
- iii. Prepare C-Channel for frame and reinforcing steel rod.
- iv. Clean C-Channel and steel rod.
- v. Pour and cure concrete.
- vi. Check color code and operating height of Spring Isolators as per approved material submittal.
- vii. Locate the Inertia Block on the plinth with temporary supports at proper height, install expansion bolts in the plinth.
- viii. Install Spring Isolators at Inertia block base. Fix bolts, washers, nuts on Spring Isolators and expansion bolts.
- ix. Remove temporary supports and level the Inertia Block by adjusting Spring Isolator.
- x. After installation, check visual appearance and mechanical security.
- xi. Check the cleanness and freedom from obstruction.

2. Installation of a Equipment and Accessories

- i. Check the dimensions of Equipment base and the mounting points.
- ii. Check and install expansion bolts in the Inertia Block.



**METHOD STATEMENT – FIRE  
FIGHTING EQUIPMENTS**



- iii. Install the pump on the Inertia Block and fix bolts, washers, nuts on Equipment base and expansion bolts.
- iv. After installation, check visual appearance and mechanical security.
- v. Check the cleanness and freedom from obstruction.

**References:**

1. Manufacturer's catalogue for pipes, fittings, supports, valves etc.
2. Approved material submittal / Technical Data Sheets
3. Approved Shop drawings Issued for Construction.
4. WPS/PQR.

**8.0 Design & Drawings**

Manufacturers Catalogues and Final approved layout drawings.

**9.0 Quality**

Procedures described in the Method Statement (MS) for FIRE FIGHTING EQUIPMENTS shall be followed and use following Quality Formats:

- Inspection Test Plan (ITP)
- Installation, testing and Commissioning Checklist (ICL)

**10.0 Distribution**

Distribution of documents shall be as per contractual Specification and agreed protocols.

\*\*\*\*\*



**STRABAG**METHOD STATEMENT – FIRE  
FIGHTING PIPING**MUMBAI TRANS HARBOUR LINK PROJECT (MTHL)****IFB No.: MMRDA/ENG1/0002561:**

Document No.	Document Name		Document Revision
0019	METHOD STATEMENT – FIRE FIGHTING PIPING		R00
	<b>Prepared By</b>	<b>Checked By</b>	<b>Approved By</b>
<b>Name</b>	Sandeep	Mubashshir	Anuj
<b>Designation</b>	Manager	DGM	GM
<b>Date</b>	29.11.2021	29.11.2021	29.11.2021





## METHOD STATEMENT – FIRE FIGHTING PIPING



### 1.0 Purpose

The purpose of this procedure is to provide guidelines to carry out all the activities in a systematic way for Fabrication and Erection of Piping and to ensure that all concerned personnel have the common understanding to achieve the highest quality of workmanship and the safe execution of the job

### 2.0 Scope

This procedure describes the stage wise fabrication & erection method of all piping work comes under Strabag scope in line with the specification and procedures for MTHL Project. This procedure may be modified to suit at site condition during the fabrication & Installation of piping work.

### 3.0 Reference

- 3.1 Project Quality Plan
- 3.2 Contract Technical Specifications
- 3.3 Approved Technical Data Sheets
- 3.4 Design Intent Drawings & Approved Shop Drawings
- 3.5 Manufacturers Catalogues & Recommendations

### 4.0 Abbreviations:

Project: MTHL  
 Client: MMRDA  
 Contractor: **STRABAG**  
 MS – Method Statement  
 FQP – Field Quality Plan  
 ICL – Installation Check List  
 CCL – Commissioning Check list  
 MHS – Material Handling System Checklist  
 MQAP – Manufacturer Quality Assurance Plan

### 5.0 Responsibilities

#### 5.1 Project Manager (Site In-charge):

- a) Ensure all required submittals area made and required plant, tools, material manpower is available in timely manner.
- b) Ensure all execution of works are carried out according to approvals, contract specifications, and approved shop drawings, MS, FQP, ICL and CCL.



**METHOD STATEMENT – FIRE  
FIGHTING PIPING**



- c) Ensure necessary coordination with all involved for timely completion of job.
- d) Will attend all site review and progress review meeting time to time.
- e) Overall responsibility of the site.

**5.2 Site Engineer:**

- a) Timely provision of relevant and complete information, approved documents and instructions to site execution / installation team.
- b) Proper execution of works as per approved documents, MS, Drawings.
- c) The implementation of the procedures mentioned in MS with the help of concerned site engineer/ site supervisors.
- d) To carry out site work activities with regards to quality and safety requirements coordinating with site quality and safety representatives.

**5.3 Site Quality Engineer:**

- a) Identified Site Quality Engineer is responsible for preparation of project specific quality documents in consultation and support from regional quality representative.
- b) Responsible for communicating with all site staff about Quality requirements and responsible for reviewing all related documents.
- c) Responsible for conducting Tool Box talk meeting along with Site Incharge & Site Engineers for training to site technicians staff
- d) Responsible for incoming material inspection & accordingly raising MIR (Material Inspection Request) for PMC/ Client inspection
- e) Responsible for daily site audits and recording of observation with photographs
- f) Responsible for installation inspection and verification of Installation checklists filled by Site supervisors
- g) Raising the SIR (Site Inspection Request) for PMC/ Client inspection
- h) Responsible for corrective actions in coordination with Project Manager & Site Engineer and close the non-conformity identified during quality audits

**6 Tools/ Equipments/ Instruments used during site execution**

Plant and equipment required for this activity as per listed below.

**6.0 Lifting & Shifting Equipment**

**6.1 Metal to metal Joining apparatus (Welding/Brazing/Soldering etc. as required)**

**6.2 Pipe Cutting devices (Gas cutting set/disc cutter/Saw cutter/hack saw/etc.)**

**6.3 Rubbing device (files/ polish papers/grinders/sharp edge remover/buffing device/etc.)**

**6.4 Flaring device ( as per standard specification if required)**

**6.5 General conventional equipment's for adjusting & fixing (Drill Machin, spanner , hammer, screw driver , screw driver, pipe wrench and sockets, etc.)**

**6.6 Scaffolding, ladders, platform, etc.**





**METHOD STATEMENT – FIRE  
FIGHTING PIPING**



**7.0 Construction Method and Sequence of Work**

**7.1 Piping**

Purpose of this is to outline the method of storage, handling, fabrication; installation of Piping.

**Material:**

- a) Pipes: ERW, GI etc., As per approved material Submittals.
- b) Supports: as per approved schedule/typical fixing drawing. Clevis hangers, U Strap / U Bolts, angles / channels, threaded rods, anchor fasteners, Nuts, Washers etc. as per approved drawings/schedule.
- c) Consumables: For processes like Welding/brazing/ soldering/heating/gluing required support material like electrodes /flux/ adhesive/fasteners/ gas/ etc.

**References**

- a) Manufacturer's catalogue for pipes, fittings, supports, valves etc.
- b) Approved material submittal / Technical Data Sheets
- c) Approved Shop drawings Issued for Construction.
- d) WPS/PQR.

**Method:**

**a) Storage:**

- i) Pipes shall be stacked on a flat surface with adequate supports as per load with display ID No.
- ii) While stacking, it shall be ensured that pipes of bigger sizes are placed below and smaller sizes are on top. Ensure the packing below bottom layer of Pipes.
- iii) Any items found damaged or not suitable as per project requirements shall be removed from site. If required to store temporarily, they shall be clearly marked and stored separately to prevent any advertent use.

**b) Preparation:**

- i) Check and ensure all drawings used for installation are latest and approved for construction
- ii) Check the co-ordination of piping layout with other services and reflected ceiling decide pipe route shall be as per approved drawing only, any deviation to be inform to ORL site, to be executed after approval.
- iii) Check and ensure sufficient clearance is available around pipe for of valves, vents etc.
- iv) Fabricate the structural supports from angles/channels as per support schedule mentioned in the drawings. Ancillary supporting material shall be hot dip galvanized.
- v) Clean and apply primer / red oxide on all ERW black pipes, prior to start installation. what about welded joints for pipe size mote than 65 MM





**METHOD STATEMENT – FIRE  
FIGHTING PIPING**



**c) Installation**

**Piping:**

- i) Fix all pipe structural supports as applicable. (as per approved drawing/ schedule)
- ii) Cut the pipes accurately to measurements determined at site.( recommended as- For smaller sizes (up to 150 mm) disc cutter should be used , for bigger sizes gas cutting.) The cut ends should be clean, clear and free from slag etc.
- iii) Ensure cut ends are square and free of dents.End preparations for weld/braze/solder/threading/grooving joints shall be done as per approved specification (For welding -WPS). (Refer welding/brazing/soldering/threading/grooving procedure) (For PVC-refer manufacturer recommended gluing/ threading method).
- iv) After the end preparation clean the pipe ends and ensure no material and dust is left inside.
- v) Depending on site conditions, assemble the piping into manageable lengths on the floor. Using threaded, welded, glued, and heated jointing as applicable, and then places the same at defined position or vice-versa.,
- vi) Install the pipe spools at heights with supports as per approved drawings in a neat and tidy manner.
- vii) Align and level the piping as per approved drawings.
- viii) Install the G.I. rod type U-Bolts for horizontal & vertical pipes as per approved schedule of supports / Typical Installation Details.
- ix) Use standard fittings like Elbows for changes of directions and branch take off to connect two ends.
- x) Pipe should be lift by using of chain pulley as per pipes weight and length. Please provide specific information
- xi) Use eccentric reducers with level side up for change of pipe sizes in horizontal runs and concentric reducers for change of sizes in Vertical runs / risers.(Eccentric reducers not applicable for threaded joints.)
- xii) Install drain points in mains, risers and branch lines consisting of tee fitting / socket ,ball valve, short nipple and cap / end plug, etc. ( u trap with right dimension should be provided wherever specified – drain/long length refrigeration piping).
- xiii) Install Air Vents along with isolation valve at higher points





**METHOD STATEMENT – FIRE  
FIGHTING PIPING**



- xiv) No Sliding or Unsupported pipe to be left on elevation.
- xv) Check and ensure proper supporting is provided as per approved drawings and support schedule.
- xvi) Ensure support completed before work end.
- xvii) Make temporary tapping provisions at multiple points for easy and quick filling and draining of pressure testing water. All the provisions are protected with isolation valve & end plug
- xviii) Visual Inspection to be carried out against welding joints in pipe as specified.
- xix) Ensure Pressure, PTW, Emergency measures handling.
- xx) Do the pressure testing of pipes as specified. After completion of pressure testing, clean the pipes, joints etc. and clear to carry out further operation like painting/insulation/cladding etc. as specified by offering to the consultant/customer.
- xxi) After completion do the pipe identification as per tender specification and approval of the consultant.

**d) Pressure Testing:**

The purpose of this outline method of pressure testing wherever applicable for piping. (Hydraulic). Please provide job specific information.

**7. 2) Painting Procedures:**

**Pre Painting procedure**

- Prior to commencement of work Project Engineer to check all pipes, paint material and documents related to section of works. Ensuring material as per approved submittals.
- QC to check inward material with proper DC and TC.
- QC Engineer to check physical verification for any damages.

Points to be checked prior to commencement of works.

- Pipes are finished with inspection
- The working area to be clean.

Site Engineer to give proper instruction to painter and helper. Supervisor to provide proper tools to carry out the work. Safety Precaution to be explained to painter and helper.

**Inspection Guidelines.**

The Supervisor will complete the inspection checklist and follow the inspection checklist and follow the inspection & Test Plan detailed in this procedure.





**STRABAG****METHOD STATEMENT – FIRE  
FIGHTING PIPING**

QA/QC should verify the approached procedures are followed.

**Painting Procedure**

- Pipe will be cleaned from Rust, Dust, Foreign materials with the help of cloth / Wire Brush.
- Pipes will be painted by means of paint brush / Roller.
- MS Structural steel shall be painted by Blackcolour.
- The Supervisor and QA/QC will monitor the activities to ensure that all components are properly painted.
- For FPS Pipes to be painted with 1 coat of Etch Primer and then with 2 coats of PO Red paint.
- For Utility Pipes to be painted with 1 coats of Epoxy Primer and then with 2 coats of Light blue paint suitable tagging & arrow marking to be incorporated.

**Quality Assurance and Policy**

We will provide integrated systems with products and services to customer's acceptability and satisfaction. We achieve the target as per schedule.

**7.3) Wrapping And Coating: for underground & external piping only****General:**

As far as possible the tapes should be applied over the pipe just prior to burial to avoid damage to coating during transportation of the coated pipes. In case any damage takes place during transportation the same will be repaired by cleaning that place and applying fresh tape coating at the damaged place.

**Surface Preparation:**

The pipe is made free of oil grease etc., by proper cleaning by cloth or by wire brushing in the local areas. The cleaned exterior of the pipe surface shall be protected from condition of high humidity, rainfall or surface moisture. All cleaned surfaced shall be coated immediately.

**Primer Application:**

Prior to primer application Proper Floor protection, Ventilation, MSDS, Task PPE and other precautions to be verified. Prior to black Paint application the pipe shall be cleaned to remove any wetness contamination. The primer shall be kept at a covered area and the quantity required should only be taken out from the drum and brought to site. Before removing the black Paint from the drum, it should be thoroughly agitated to ensure uniformity of the black Paint. The black Paint is then to be applied uniformly by means of a brush on the cleaned surface of the pipe; leaving no drops or runs and then allowed to become touch dry.

**Tape Installation:**

After the surface is primed, 4 mm Anti Corrosive tape is applied over the pipe by thermo-fusion process. The 4mm Polyethylene HMHDPE film is removed from the tape by pulling it manually.



**STRABAG****METHOD STATEMENT – FIRE  
FIGHTING PIPING****एम एम आर डी ए  
MMRDA**

An LPG torch is applied onto the lower face of the tape till the polymeric mix attains shiny appearance. The primed surface may be gently heated by a run of LPG torch and the tape is then adhered to the primer-coated surface. Overlaps of minimum 15 mm shall be maintained. The top expand layers of HMHDPE will also be removed from the applied tape by pulling it manually.

Note:- Only Industrial LPG with approved regulator, Back fire arrester & Signage will be use with Storage Limit.

**7.4) Inspection:**

All the coated and wrapped pipes shall be tested with an approved high voltage Holiday Detector.

**7.5) Handling of Coated Pipes:**

- All coated pipes shall be handled in such a way that the coating doesn't damage.
- Coated pipe shall be handled at all times with wide non-abrading slings or belts, or other equipment designed to prevent damage to the coating.
- Pipe shall normally be lowered into the trench immediately after the coating and wrapping has been approved. Where coated and wrapped pipe is supported by sufficient number of supports to ensure that no damage will be caused to the coating and wrapping.
- All coated and wrapped pipes which have been supported in any manner shall be subjected to closed inspection to see that the coating is undamaged before the pipe reaches the bottom of the trench. Backfilling shall be carried out immediately after the pipeline is lowered into the trench.

**8.0 Design & Drawings**

Manufacturers Catalogues and Final approved layout drawings.

**9.0 Quality**

Procedures described in the Method Statement (MS) for Installation of FIRE FIGHTING piping shall be followed and use following Quality Formats:

- Inspection Test Plan (ITP)
- Installation, testing and Commissioning Checklist (ICL)

**10.0 Distribution**

Distribution of documents shall be as per contractual Specification and agreed protocols.

\*\*\*\*\*



**STRABAG**METHOD STATEMENT –  
PLUMBING EQUIPMENTS

**एम एम आर डी ए**  
MMRDA
**MUMBAI TRANS HARBOUR LINK PROJECT (MTHL)****IFB No.: MMRDA/ENG1/0002561:**

Document No.	Document Name		Document Revision
0020	METHOD STATEMENT – PLUMBING EQUIPMENTS		R00
	<b>Prepared By</b>	<b>Checked By</b>	<b>Approved By</b>
<b>Name</b>	Sandeep	Mubashshir	Anuj
<b>Designation</b>	Manager	DGM	GM
<b>Date</b>	29.11.2021	29.11.2021	29.11.2021



**STRABAG****METHOD STATEMENT –  
PLUMBING EQUIPMENTS****एम एम आर डी ए  
MMRDA****1.0 Purpose**

The purpose of this procedure is to detail the necessary criteria for installation work Of Equipment (pumps, tank, sanitary fixture etc. ) as per approved shop drawings and manufacturer's recommendations, to produce a quality installation conforming to relative standards and project specifications.

**2.0 Scope**

This method statement refers to various work procedures contained within Strabag project quality plan and Contract specifications which explains and covers the Water supply Hydro pneumatic and all other transfer Pump installation as well as other equipment.

**3.0 Reference**

- 3.1 Project Quality Plan
- 3.2 Contract Technical Specifications
- 3.3 Approved Technical Data Sheets
- 3.4 Design Intent Drawings & Approved Shop Drawings
- 3.5 Manufacturers Catalogues & Recommendations

**4.0 Abbreviations:**

Project: MTHL  
 Client: MMRDA  
 Contractor: **STRABAG**  
 MS – Method Statement  
 FQP – Field Quality Plan  
 ICL – Installation Check List  
 CCL – Commissioning Check list  
 MHS – Material Handling System Checklist  
 MQAP – Manufacturer Quality Assurance Plan

**5.0 Responsibilities****5.1 Project Manager (Site In-charge):**

- a) Ensure all required submittals area made and required plant, tools, material manpower is available in timely manner.
- b) Ensure all execution of work is carried out according to approvals, contract specifications, and approved shop drawings, MS, FQP, ICL and CCL.
- c) Ensure necessary coordination with all involved for timely completion of job.



**STRABAG****METHOD STATEMENT –  
PLUMBING EQUIPMENTS****एम एम आर डी ए  
MMRDA**

- d) Will attend all site review and progress review meeting time to time.
- e) Overall responsibility of the site.

**5.2 Site Engineer:**

- a) Timely provision of relevant and complete information, approved documents and instructions to site execution / installation team.
- b) Proper execution of works as per approved documents, MS, Drawings.
- c) The implementation of the procedures mentioned in MS with the help of concerned site engineer/ site supervisors.
- d) To carry out site work activities with regards to quality and safety requirements coordinating with site quality and safety representatives.

**5.3 Site Quality Engineer:**

- a) Identified Site Quality Engineer is responsible for preparation of project specific quality documents in consultation and support from regional quality representative.
- b) Responsible for communicating with all site staff about Quality requirements and responsible for reviewing all related documents.
- c) Responsible for conducting Tool Box talk meeting along with Site Incharge & Site Engineers for training to site technicians staff
- d) Responsible for incoming material inspection & accordingly raising MIR (Material Inspection Request) for PMC/ Client inspection
- e) Responsible for daily site audits and recording of observation with photographs
- f) Responsible for installation inspection and verification of Installation checklists filled by Site supervisors
- g) Raising the SIR (Site Inspection Request) for PMC/ Client inspection
- h) Responsible for corrective actions in coordination with Project Manager & Site Engineer and close the non-conformity identified during quality audits

**6.0 Tools/ Equipments/ Instruments used during site execution**

Plant and equipment required for this activity as per listed below.

**6.1 Lifting & Shifting Equipment**

6.2 General conventional equipment's for adjusting & fixing (spanner, hammer, screw driver, screw driver, pipe wrench and sockets, etc.)

6.3 Scaffolding, ladders, platform, Chain Block etc.

**7.0 Construction Method and Sequence of Work****7A. Installation Procedure for pump****General :**

This method statement describes the installation of Water supply Hydro pneumatic and all other



**STRABAG****METHOD STATEMENT –  
PLUMBING EQUIPMENTS****एम एम आर डी ए  
MMRDA**

transfer Pump. Detail of the procedure contained herein may be modified based on the actual site condition.

**Material:**

- 7.1.1 Chain pulley blocks
- 7.1.2 Wooden slippers
- 7.1.3 Hydraulic jacks
- 7.1.4 Solid pipes
- 7.1.5 Wire rope

**References:**

- a) Manufacturer's catalogue for Pumps, fittings, supports, Inertia base etc.
- b) Approved material submittal / Technical Data Sheets
- c) Approved Shop drawings Issued for Construction.
- d) WPS/PQR/WPQ(welder qualification), as per ASME.

**Method:****a) Storage:**

- i) Pumps shall be stacked on a flat surface with adequate supports.
- ii) Any items found damaged or not suitable as per project requirements shall be removed from site. If required to store temporarily, they shall be clearly marked and stored separately to prevent any advertent use

**b) Preparation:**

- i) Check and ensure all drawings used for installation are latest and approved for construction.
- ii) Check the co-ordination pumps installation layout with other services.
- iii) Check and ensure sufficient clearance is available between two pumps and valve stations.
- iv) Fabricate the structural supports from angles/channels as per support schedule mentioned in the drawings. Ensure all supports are Hot deep Galvanized.

**c) Installation****Note:**

Prior to start installations one sample installation as per approved drawings and project specifications to be made and offered for Consultant / customer for Inspections.

**1 Installation of Inertia Block and Spring Isolator:**

- a. Check the dimensions of pump base and the mounting points.
- b. Check size, height and mounting points to mount to pump base and to plinth
- c. of Inertia Block.
- d. Prepare C-Channel for frame and reinforcing steel rod.
- e. Clean Galvanized C-Channel and steel rod.



**STRABAG****METHOD STATEMENT –  
PLUMBING EQUIPMENTS**

- f. Pour and cure concrete.
- g. Check color code and operating height of Spring Isolators as per approved materials technical submittals.
- h. Locate the Inertia Block on the plinth with temporary supports at proper
- i. height, install expansion bolts in the plinth.
- j. Install Spring Isolators at Inertia block base. Fix bolts, washers, nuts on
  - i. Spring Isolators and expansion bolts.
- k. Remove temporary supports and level the Inertia Block by adjusting Spring
  - i. Isolator.
- l. After installation, check visual appearance and mechanical security.
- m. Check the cleanness and freedom from obstruction.

**1 Installation of a Pump and Accessories:**

- i. Check the dimensions of pump base and the mounting points.
- ii. Check and install expansion bolts in the Inertia Block.
- iii. Install the pump on the Inertia Block and fix bolts, washers, nuts on pump base and expansion bolts.
- iv. After installation, check visual appearance and mechanical security.
- v. Check the cleanness and freedom from obstruction.
- vi. Manufacturer joint inspection shall be call for after complete integration of system

**References:**

- a) Manufacturer's catalogue for pipes, fittings, supports, valves etc.
- b) Approved material submittal / Technical Data Sheets
- c) Approved Shop drawings Issued for Construction.
- d) WPS/PQR/WPQ(welder qualification),as per ASME.

**7B. Installation Procedure of equipment (like tank, sanitary fixture etc.)****General :**

This method statement describes the installation of equipment (like Tank, sanitary fixture etc). Detail of the procedure contained herein may be modified based on the actual site condition.

**Material**

- a) Chain pulley blocks
- b) Wooden slippers
- c) Hydraulic jacks
- d) Solid pipes
- e) Wire rope

**References** Client supply item shall be specified separately.

- a) Manufacturer's catalogue for equipment, fittings, supports, Inertia base etc.
- b) Approved material submittal / Technical Data Sheets
- c) Approved Shop drawings Issued for Construction.
- d) WPS/PQR/WPQ(welder qualification),as per ASME.

**Method:**

**STRABAG****METHOD STATEMENT –  
PLUMBING EQUIPMENTS****a) Storage:**

Equipment shall be stacked on a flat surface with adequate supports. Any items found damaged or not suitable as per project requirements shall be removed from site. If required to store temporarily, they shall be clearly marked and stored separately to prevent any advertent use

**b) Preparation:**

- i) Check and ensure all drawings used for installation are latest and approved for construction
- ii) Check the co-ordination equipment installation layout with other services.
- iii) Check and ensure sufficient clearance is available between two equipment and two fixture, fitting tank etc.
- iv) Fabricate the structural supports from angles/channels as per support schedule mentioned in the drawings. Ensure all supports are Hot deep Galvanized.

**c) Installation****Note:**

Prior to start installations one sample installation as per approved drawings and project specifications to be made and offered for Consultant/customer for Inspections. **1. Installation of equipment and Accessories:**

- a. Check the dimensions of equipment & fixture base and the mounting points.
- b. Check and install expansion bolts in the Inertia Block & place of fixture.
- c. Install the equipment & fixture on the Inertia Block and fix bolts, washers, nuts on equipment base and expansion bolts.
- d. After installation, check visual appearance and mechanical security.
- e. Check the cleanness and freedom from obstruction.

**References**

1. Manufacturer's catalogue for equipment, tank, fittings, supports, valves etc.
2. Approved material submittal / Technical Data Sheets
3. Approved Shop drawings Issued for Construction.
4. WS/PQR/WPQ(welder qualification), as per ASME

**7C. Installation Procedure of CP, sanitary fixture etc.) General :**

This method statement describes the installation of CP, sanitary fixture. Detail of the procedure contained herein may be modified based on the actual site condition.

**References**

- e) Manufacturer's catalogue for CP, Sanitary fixtures etc.
- f) Approved material submittal / Technical Data Sheets
- g) Approved Shop drawings Issued for Construction.

**Method:** .



**STRABAG****METHOD STATEMENT –  
PLUMBING EQUIPMENTS****एम एम आर डी ए  
MMRDA****d) Storage:**

CP, Sanitary shall be stacked on a flat surface with adequate supports. Any items found damaged or not suitable as per project requirements shall be removed from site. If required to store temporarily, they shall be clearly marked and stored separately to prevent any advertent use

**e) Preparation:**

- v) Check and ensure all drawings used for installation are latest and approved for construction
- vi) Check the co-ordination equipment installation layout with other services.
- vii) Check and ensure sufficient clearance is available between two equipment and two fixture, fitting tank etc.

**f) Installation****Note:**

Prior to start installations one sample installation as per approved drawings and project specifications to be made and offered for Consultant / customer for Inspections. **1. Installation of CP, Sanitary fixtures:**

- e. Check the dimensions of equipment & fixture base and the mounting points.
- f. Check and install expansion bolts & place of fixture.
- g. Install the equipment & fixture and fix bolts, washers, nuts on equipment base and expansion bolts.
- h. After installation, check visual appearance and mechanical security.
- e. Check the cleanness and freedom from obstruction.

**8.0 Design & Drawings**

Manufacturers Catalogues and Final approved layout drawings.

**9.0 Quality**

Procedures described in the Method Statement (MS) for PLUMBING EQUIPMENTS shall be followed and use following Quality Formats:

- Inspection Test Plan (ITP)
- Method Statement (MS)
- Installation, testing and Commissioning Checklist (ICL)

**10.0 Distribution**

Distribution of documents shall be as per contractual Specification and agreed protocols.



**STRABAG**METHOD STATEMENT – PHE  
PIPING

**एम एम आर डी ए**  
MMRDA
**MUMBAI TRANS HARBOUR LINK PROJECT (MTHL)****IFB No.: MMRDA/ENG1/0002561:**

Document No.	Document Name		Document Revision
0021	METHOD STATEMENT – PHE PIPING		R00
	<b>Prepared By</b>	<b>Checked By</b>	<b>Approved By</b>
<b>Name</b>	Sandeep	Mubashshir	Anuj
<b>Designation</b>	Manager	DGM	GM
<b>Date</b>	29.11.2021	29.11.2021	29.11.2021



**STRABAG****METHOD STATEMENT – PHE  
PIPING****एम एम आर डी ए  
MMRDA****1.0 Purpose**

The purpose of generating this method statement is to define the procedure step by step to implement the correct practices for piping work for PLUMBING System

**2.0 Scope**

This method statement refers to various work procedures contained within Strabag project quality plan and Contract specifications which explains and covers the Piping work for PLUMBING System

**3.0 Reference****3.1 Project Quality Plan****3.2 Contract Technical Specifications****3.3 Approved Technical Data Sheets****3.4 Design Intent Drawings & Approved Shop Drawings****3.5 Manufacturers Catalogues & Recommendations****4.0 Abbreviations:**

Project: MTHL  
Client: MMRDA  
Contractor: **STRABAG**  
MS – Method Statement  
FQP – Field Quality Plan  
ICL – Installation Check List  
CCL – Commissioning Check list  
MHS – Material Handling System Checklist  
MQAP – Manufacturer Quality Assurance Plan

**5.0 Responsibilities****5.1 Project Manager (Site In-charge):**

- a) Ensure all required submittals area made and required plant, tools, material manpower is available in timely manner.
- b) Ensure all execution of works area carried out according to approvals, contract specifications, and approved shop drawings, MS, FQP, ICL and CCL.
- c) Ensure necessary coordination with all involved for timely completion of job.
- d) Will attend all site review and approval review meeting time to time.
- e) Overall responsibility of the site.



**STRABAG****METHOD STATEMENT – PHE  
PIPING****M** एम एम आर डी ए  
MMRDA**5.2 Site Engineer:**

- a) Timely provision of relevant and complete information, approved documents and instructions to site execution / installation team.
- b) Proper execution of works as per approved documents, MS, Drawings.
- c) The implementation of the procedures mentioned in MS with the help of concerned site engineer/ site supervisors.
- d) To carry out site work activities with regards to quality and safety requirements coordinating with site quality and safety representatives.

**5.3 Site Quality Engineer:**

- a) Identified Site Quality Engineer is responsible for preparation of project specific quality documents in consultation and support from regional quality representative.
- b) Responsible for communicating with all site staff about Quality requirements and responsible for reviewing all related documents.
- c) Responsible for conducting Tool Box talk meeting along with Site Incharge & Site Engineers for training to site technicians staff
- d) Responsible for incoming material inspection & accordingly raising MIR (Material Inspection Request) for PMC/ Client inspection
- e) Responsible for daily site audits and recording of observation with photographs
- f) Responsible for installation inspection and verification of Installation checklists filled by Site supervisors
- g) Raising the SIR (Site Inspection Request) for PMC/ Client inspection
- h) Responsible for corrective actions in coordination with Project Manager & Site Engineer and close the non-conformity identified during quality audits

**6.0 Tools/ Equipments/ Instruments used during site execution**

Plant and equipment required for this activity as per listed below.

- 6.1 Lifting, Shifting & excavation Equipment
- 6.2 Metal to metal Joining apparatus (Welding/Brazing/Soldering etc. as required)
- 6.3 Pipe Cutting devices (Gas cutting set/disc cutter/Saw cutter/hack saw/etc.)
- 6.4 Rubbing device (files/ polish papers/grinders/sharp edge remover/buffing device/etc.)
- 6.5 Flaring device ( as per standard specification if required)
- 6.6 General conventional equipment's for adjusting & fixing (Drill Machine, spanner , hammer, screw driver , screw driver, pipe wrench ,sockets & civil work appliances etc.)
- 6.7 Scaffolding, ladders, platform, etc.

**7.0 Construction Method and Sequence of Work****7A. Installation Procedure for PP / UPVC pipe****Solvent Joint:**

All joints for both PP / UPVC pipe will be solvent fill joints.



**STRABAG****METHOD STATEMENT – PHE  
PIPING****एम एम आर डी ए  
MMRDA****Cleaning of Piping:**

PP / UPVC Pipes are well finished pipes. All pipes shall be cleaned prior to fabrication/erection by hand remove all dust from inner surface and outer surfaces of joints to be made.

**Fabrication:**

Solvent cement would be used between Socket and spigot of pipes and fittings. For jointing of pipe to pipe make an application of solvent as mentioned in specification on plane end of pipe and push in to the socket end of pipe. Hold for a few seconds for proper sealing.

**Pipe Supports:**

Prior to installation of pipes, temporary pipe supports shall be installed (If required) or the permanent supports will be installed as specified in the drawings. Pipe support distance shall be as per technical specification. Supports shall be arrange as per location of shaft & slope to be maintain in coordination with other services.

**Expansion Joints:**

Installation of expansion joints shall be accordance with the manufacture's requirements and recommendations unless otherwise specified.

**Valves:**

Valves may be either with flanged ends or threaded ends. Valves should be installed as per approved drawings and technical specifications.

**End Caps:**

All plain end caps are to be installed as specified in the drawings.

**Testing:**

The hydro test shall be performed after completion of pipeline in all respects. The test pressure will be as per technical specification.

**7B. Installation Procedure CI/LA class pipe****Drip seal PJS joint:**

All joints for both spun/centric CI and LA class pipe will be drip seal fill joints.

**Cleaning of Piping:**

CI/LA class Pipes are well finished pipes. All pipes shall be cleaned prior to fabrication/erection by hand remove all dust from inner surface and outer surfaces of joints to be made.

**Fabrication:**

Drip seal (pipe joint sealant) shall be used for jointing various diameters of CI pipes & fittings. This sealant replaces the standard drip seal caulked joints. The application is by homogenously mixing the two part system in cold condition.

**STRABAG****METHOD STATEMENT – PHE  
PIPING****एम एम आर डी ए  
MMRDA****Application:**

Clean the pipe joints thoroughly to ensure it is free from any traces of oil, dirt or any other foreign body. Mix two parts of drip seal thoroughly with an iron flat to get a homogenous compound. \*Place spun yarn in the pipe joint as a filler and then take the required quantity of the compound and push it in the joint with a caulking tool, MS Flat / damp finger uniformly all over to obtain a smooth & uniform joint. Dip the fingers in water every often to ensure the compound dose not stick to the hands of the workman, but this will ensure perfect sealing & the smooth surface for the joint cement. (\*The Compound prepared from the two mixtures to be used in 30 minutes) precaution to be taken to wash hands thoroughly with soap before & after use. Preferably use disposal gloves for hand application.

**Pipe Supports:**

Prior to installation of pipes, temporary pipe supports shall be installed (If required) or the permanent supports will be installed as specified in the drawings. Pipe support distance shall be as per technical specification. Supporting arrangement must comply required Slope & bottom of pipe in coordination with other services.

**Expansion Joints:**

Expansion joints will not be required to be installed in drainage pipes.

**Valves:**

Valves will not be required to be installed in drainage pipes.

**End Caps:**

All plain end caps are to be installed as specified in the drawings.

**Testing:**

Water flow test will be done to ensure clog free and leakage free operation of pipes.

**7C. Installation Procedure of G.I./MS/Copper pipes****Piping:**

Purpose of this is to outline the method of storage, handling, fabrication, installation of Piping.

**Material:**

- Pipes: As per approved material submittals.
- Supports: as per approved schedule/typical fixing drawing. Clevis hangers, U Strap / U Bolts, angles / channels, threaded rods, anchor fasteners, Nuts, Washers etc. as per approved drawings/schedule.
- Consumables: For processes like Welding / brazing / soldering / heating / gluing / threading required support material like electrodes /flux/ adhesive/fasteners/ gas/ etc.

**References**

Page 5 | 7

2179

**STRABAG****METHOD STATEMENT – PHE  
PIPING****एम एम आर डी ए  
MMRDA**

- a) Manufacturer's catalogue for pipes, fittings, supports, valves etc.
- b) Approved material submittal / Technical Data Sheets
- c) Approved Shop drawings Issued for Construction.
- d) WPS/PQR.

**Method:****a) Storage:**

- i) Pipes shall be stacked on a flat surface with adequate supports
- ii) While stacking, it shall be ensured that pipes of bigger sizes are placed below and smaller sizes are on top. Ensure the packing below bottom layer of Pipes.
- iii) Any items found damaged or not suitable as per project requirements shall be removed from site. If required to store temporarily, they shall be clearly marked and stored separately to prevent any advertent use

**b) Preparation:**

- i) Check and ensure all drawings used for installation are latest and approved for construction.
- ii) Check the co-ordination of piping layout with other services and reflected ceiling and decide pipe route with minimum bends/offsets.
- iii) Check and ensure sufficient clearance is available around pipe for valves, vents etc.
- iv) Fabricate the structural supports from angles/channels as per support schedule mentioned in the drawings.
- v) Clean and apply primer / red oxide on all ERW black pipes, prior to start installation.

**c) Installation:****Piping:**

- i. Fix all pipe structural supports as applicable. (as per approved drawing/ schedule)
- ii. Cut the pipes accurately to measurements determined at site. (recommended as- For smaller sizes (up to 100 mm) disc cutter should be used, for bigger sizes gas cutting.) The cut ends should be clean, clear and free from slag etc.
- iii. Ensure cut ends are square and free of dents.
- iv. Threading/flaring shall be done as per fitting / valve manufacturer's recommendations (NPT or BS Threads)
- v. End preparations for weld/braze/solder/threading joints shall be done as per approved specification (For welding -WPS). (Refer welding/brazing/soldering procedure)(For PVC- refer manufacturer recommended gluing/ threading method).
- vi. After the end preparation clean the pipe ends and ensure no material and dust is left inside.
- vii. Depending on site conditions, assemble the piping into manageable lengths on the floor. Using threaded, welded and heated jointing as applicable, and then place the same at definite position or vice-versa.,
- viii. Install the pipe spools at heights with supports as per approved drawings in a neat and



**STRABAG****METHOD STATEMENT – PHE  
PIPING****एम एम आर डी ए  
MMRDA**

- tidy manner.
- ix. Align and level the piping as per approved drawings.
  - x. Install the G.I. rod type U-Bolts for horizontal & vertical pipes as per approved schedule of supports / Typical Installation Details.
  - xi. Use standard fittings like Elbows for changes of directions and branch take off to connect two ends.
  - xii. Use eccentric reducers with level side up for change of pipe sizes in horizontal runs and concentric reducers for change of sizes in Vertical runs / risers.
  - xiii. Install drain points in mains, risers and branch lines consisting of tee fitting / socket , ball valve, short nipple and cap / end plug, etc. ( u trap with right dimension should be provided wherever specified – drain/long length refrigeration piping )
  - xiv. Install Air Vents along with isolation valve at higher points.
  - xv. Check and ensure proper supporting is provided as per approved drawings and support schedule.
  - xvi. Make temporary tapping provisions along with isolation valve / dead plug at multiple points for easy and quick filling and draining of pressure testing water.
  - xvii. Visual Inspection to be carried out against Welding/Brazing joints in pipe as specified.
  - xviii. Do the pressure testing of pipes as per Technical specification. After completion of pressure testing, clean the pipes, joints etc. and clear to carry out further operation like painting/insulation/cladding etc. as specified by offering to the consultant/customer.
  - xix. After completion do the pipe identification as per tender specification and approval of the consultant

**Pressure Testing:**

The purpose of this outline method of pressure testing wherever applicable for piping.

**8.0 Design & Drawings**

Manufacturers Catalogues and Final approved layout drawings.

**9.0 Quality**

Procedures described in the Method Statement (MS) for PHE Piping shall be followed and use following Quality Formats:

- Inspection Test Plan (ITP)
- Method Statement (MS)
- Installation, testing and Commissioning Checklist (ICL)

**10.0 Distribution**

Distribution of documents shall be as per contractual Specification and agreed protocols.





Technical Proposal

Mobilization Schedule



**STRABAG****Tentative Mobilization Schedule**

**एम एम आर डी ए**  
**MMRDA**
**MUMBAI TRANS HARBOUR LINK PROJECT (MTHL)****Tentative Mobilization Schedule - of major items of the equipment (Contractor's Equipment) proposed**

Sr. No.	Equipment/ Machinery	Expected time of arrival (weeks from effective date)	Location of arrival
1	Hydra	Week 40 onwards	Mumbai
2	Crane	Week 45 onwards	Mumbai
3	Fork Lift	Week 40 onwards	Mumbai
4	Tractor Trolley	Week 40 onwards	Mumbai
5	Construction Tools	Week 40 onwards	Mumbai
6	Instrument for testing	Week 60 onwards	Mumbai

Note: All the Equipment/ Machinery/ Tools and Tackles required for the smooth and timely execution of the project shall be deployed as per the project requirement and site front availability



Technical Proposal

Mobilization Schedule

Equipment List



**STRABAG**

List of equipments

**MUMBAI TRANS HARBOUR LINK PROJECT (MTHL)****IFB No.: MMRDA/ENG1/0002561:**

Document No.	Document Name		Document Revision
0002	<b>List of equipments</b>		R00
	<b>Prepared By</b>	<b>Checked By</b>	<b>Approved By</b>
<b>Name</b>	Sandeep	Mubashshir	Anuj
<b>Designation</b>	Manager	DGM	GM
<b>Date</b>	29.11.2021	29.11.2021	29.11.2021



**STRABAG**

## List of equipments



List of Equipments				
S.No.	Description	Owned or Leased	Unit	Qty.
1.	Crane	Leased	Nos	As Required
2.	Crane Mounted Vehicle	Leased	Nos	As Required
3.	Forklift	Leased	Nos	As Required
4.	Tractor Trolley	Leased	Nos	As Required
List of the Tools				
S.No.	Description	Owned or Leased	Unit	Qty.
1.	Drilling Machine	Owned	Nos	As Required
2.	Torque Wrench	Owned	Nos	As Required
3.	Aluminium ladder 3 Mtr	Owned	Nos	As Required
4.	Aluminium ladder 5 Mtr	Owned	Nos	As Required
5.	Vibration Meter	Owned	Nos	As Required
6.	Noise Level Meter	Owned	Nos	As Required
7.	Anemometer	Owned	Nos	As Required
8.	Tachometer	Owned	Nos	As Required
9.	Megger	Owned	Nos	As Required
10.	Tong Tester	Owned	Nos	As Required
11.	Pitot Tube	Owned	Nos	As Required
12.	Air Flow Manometer	Owned	Nos	As Required
13.	Dry and wet Bulb Thermometer	Owned	Nos	As Required
14.	Digital Multi meter	Owned	Nos	As Required
15.	Side cutting plier	Owned	Nos	As Required
16.	Centre Punch 6",12"	Owned	Nos	As Required
17.	File Flat	Owned	Nos	As Required
18.	Force Box 2462	Owned	Nos	As Required
19.	Extension 250mm & 125mm	Owned	Nos	As Required
20.	Monkey plier	Owned	Nos	As Required
21.	Adjustable wrench	Owned	Nos	As Required
22.	Line Tester	Owned	Nos	As Required
23.	Nose plier	Owned	Nos	As Required
24.	Mallet	Owned	Nos	As Required
25.	Ball Hammer	Owned	Nos	As Required
26.	Combination plier 8"	Owned	Nos	As Required
27.	Allen key set	Owned	Nos	As Required
28.	One Side ring & one side open spanner (8,10,13,15,17,19,21,24,27,30,32)	Owned	Nos	As Required
29.	One side ring & one side open spanner set	Owned	Nos	As Required



**STRABAG**

## List of equipments



30.	Phillips screwdriver 12" or of equivalent MAKE	Owned	Nos	As Required
31.	Phillips screwdriver 8" or of equivalent MAKE	Owned	Nos	As Required
32.	Screwdriver 6"	Owned	Nos	As Required
33.	Wire stripper	Owned	Nos	As Required
34.	Torch LED Type	Owned	Nos	As Required
35.	Socket spanner (8,10,13,15,17,19) mm	Owned	Nos	As Required
36.	Blower	Owned	Nos	As Required
37.	Vernier Calliper	Owned	Nos	As Required
<b>Instrument for testing</b>				
S.No.	Description	Owned or Leased	Unit	Qty.
1.	Anemometer	Owned	Nos	As Required
2.	Pitot tubes of various lengths to suit duct sizes	Owned	Nos	As Required
3.	Mercury in glass thermometers/ Sling Psychrometer	Owned	Nos	As Required
4.	Digital thermometer	Owned	Nos	As Required
5.	Weekly recording thermometers	Owned	Nos	As Required
6.	Weekly recording RH meters	Owned	Nos	As Required
7.	Specially mounted anemometers fixed in a conical sheet metal box hood for measuring accurately air flow from diffusers	Owned	Nos	As Required
8.	Tachometer	Owned	Nos	As Required
9.	Digital clamp meter/ Multi meter	Owned	Nos	As Required
10.	U tube manometer and water balancing instruments	Owned	Nos	As Required
11.	Vibration and Noise testing instruments	Owned	Nos	As Required
12.	Surface contact dial indicating pyrometer	Owned	Nos	As Required



**STRABAG**

## List of equipments



## List of Equipments - Toll Management System Equipments

S.No.	Description	Owned or Leased	Unit	Qty.
1.	Toll Management System	Owned	Nos	As Required

## List of the Equipments - Highway Traffic Management System Equipment

S.No.	Description	Owned or Leased	Unit	Qty.
1.	Emergency Call Box (ECB)	Owned	Nos	As Required
2.	Closed Circuit Television (CCTV) for traffic	Owned	Nos	As Required
3.	Closed Circuit Television (CCTV) for security	Owned	Nos	As Required
4.	Video Incident Detection System (VIDS)	Owned	Nos	As Required
5.	Automatic Traffic Counters-cum- classifier (ATCC)	Owned	Nos	As Required
6.	Meteorological Data System (MET)	Owned	Nos	As Required
7.	Variable message sign (VMS)	Owned	Nos	As Required
8.	Vehicle Actuated Speed Warning System (VASS)	Owned	Nos	As Required



Technical Proposal

Mobilization Schedule

Form EQU





## Form EQU: Equipment

Date: 09/12/2021

Bidder's Legal Name: JV of STRABAG Infrastructure &amp; Safety Solutions GmbH and STRABAG AG

Joint Venture Party Legal Name: STRABAG Infrastructure &amp; Safety Solutions GmbH.

IFB No.: MMRDA/ENG1/0002561

Page 1 of 1

Item of Contractor's Equipment proposed: TMS System		
Equipment information	Name of manufacturer: EFKON India Pvt. Ltd.	Model and power rating: As per solution design
	Capacity: As per solution design	Year of manufacture: As per delivery schedule
Current status	Current location: Mumbai	
	Details of current commitments: Planning, design and construction of Intelligent Transport System (ITS), Toll Management System (TMS) and Advanced Traffic Management System (ATMS)	
Source	Indicate source of the equipment: [tick an appropriate box] <input type="checkbox"/> Owned <input type="checkbox"/> Rented <input type="checkbox"/> Leased <input checked="" type="checkbox"/> Specially Manufactured	
Remarks	<input checked="" type="checkbox"/> Catalogues, drawings and/or other similar materials are attached. <input type="checkbox"/> Catalogues, drawings and/or other similar materials are not attached.	



STRABAG Infrastructure & Safety Solutions GmbH  
Ignaz-Koeck-Str. 19  
1210 Wien/Österreich  
www.strabag-iss.com

Sitz: Wien, Handelsgericht Wien, FN 79686p, UID Nr. ATU14764502

Gedruckt auf 100 % Recyclingpapier



Tel: +43 1 90199-0  
Fax: +43 1 90199-19  
siss-office@strabag.com

Raffisonlandesbank Oberösterreich  
IBAN: AT91 3400 0000 0014 1317  
BIC: SWIFT RZ00AT2LXXX



2190

## Form EQU: Equipment

Date: 09/12/2021

Bidder's Legal Name: JV of STRABAG Infrastructure &amp; Safety Solutions GmbH and STRABAG AG

Joint Venture Party Legal Name: STRABAG Infrastructure &amp; Safety Solutions GmbH IFB No.:

MMRDA/ENG1/0002561

Page 1 of 1

Item of Contractor's Equipment proposed: HTMS System		
Equipment information	Name of manufacturer: EFKON India Pvt. Ltd.	Model and power rating: As per solution design
	Capacity: As per solution design	Year of manufacture: As per delivery schedule
Current status	Current location: Mumbai	
	Details of current commitments: Planning, design and construction of Intelligent Transport System (ITS), Toll Management System (TMS) and Advanced Traffic Management System (ATMS)	
Source	Indicate source of the equipment: [tick an appropriate box] <input type="checkbox"/> Owned <input type="checkbox"/> Rented <input type="checkbox"/> Leased <input checked="" type="checkbox"/> Specially Manufactured	
Remarks	<input checked="" type="checkbox"/> Catalogues, drawings and/or other similar materials are attached. <input type="checkbox"/> Catalogues, drawings and/or other similar materials are not attached.	



STRABAG Infrastructure & Safety Solutions GmbH  
Ignaz-Koeck-Str 19  
1210 Wien/Österreich  
www.strabag-iss.com

Sitz: Wien, Handelsgericht Wien, FN 79568p UID Nr.: ATU14764502

Gedruckt auf 100 % Recyclingpapier



Tel: +43 1 90199-0  
Fax: +43 1 90199-19  
siss-office@strabag.com

Raiffeisenlandesbank Oberösterreich AG  
IBAN: AT91 3400 0000 0014 1317  
BIC/SWIFT: RZODAT2LXXX



## Form EQU: Equipment

Date: 09/12/2021

Bidder's Legal Name: JV of STRABAG Infrastructure &amp; Safety Solutions GmbH and STRABAG AG

Joint Venture Party Legal Name: STRABAG Infrastructure &amp; Safety Solutions GmbH IFB No.:

MMRDA/ENG1/0002561

Page 1 of 1

Item of Equipment: <b>Crane Mounted Vehicle</b>	
Equipment Information	Name of manufacturer: <b>ESCORTS LIMITED</b>
	Model and power rating: <b>F20 4WD</b>
	Capacity: <b>20 T</b>
	Year of manufacture: <b>2019</b>
CurrentStatus	Current location: <b>Delhi</b>
	Details of current commitments: <b>Available as per Requirement</b>
Source	Indicate source of the equipment  Owned <input type="checkbox"/> Rented <input checked="" type="checkbox"/> Leased <input checked="" type="checkbox"/> Specially manufactured
Remarks	<input type="checkbox"/> Catalogues, drawings and/or other similar materials are attached. <input checked="" type="checkbox"/> Catalogues, drawings and/or other similar materials are not attached.
Owner	Name of owner: <b>M/S RASHI CRANE SERVICE</b>
	Address of owner: <b>VIVEKANAND NAGAR GALI NO-2 BAHADURGARH, JHAJJAR, HARYANA, 124507</b>
	Telephone: <b>+91-7011995937</b>
	Contact name and title: <b>Anand (Owner)</b>
	Fax: <b>NA</b>
	Telex: <b>NA</b>
Agreements	Details of rental/ lease/ manufacture agreements specific to the project
	<b>These details will be provided Later</b>



STRABAG Infrastructure & Safety Solutions GmbH  
 Ignaz-Koeck-Str 19  
 1210 Wien/Osterreich  
 www.strabag-iss.com

Tel +43 1 90199-0  
 Fax +43 1 90199-19  
 iss-office@strabag.com

Raffaellenlandesbank Oberoster Austria  
 IBAN AT91 3400 0000 0014 1317  
 BIC/SWIFT RZDOAT2LXXX

Sitz Wien Handelsgericht Wien, FN 79686p UID Nr ATU14764502

Gedruckt auf 100 % Recyclingpapier



2192

## Form EQU: Equipment

Date: 09/12/2021

Bidder's Legal Name: JV of STRABAG Infrastructure &amp; Safety Solutions GmbH and STRABAG AG

Joint Venture Party Legal Name: STRABAG Infrastructure &amp; Safety Solutions GmbH IFB No.:

MMRDA/ENG1/0002561

Page 1 of 1

Item of Equipment: Crane		
Equipment Information	Name of manufacturer: INDO FARM EQUIPMENT LTD	Model and power rating: INDO POWER 15 FN
	Capacity: 15 T	Year of manufacture: 2014
CurrentStatus	Current location: Delhi	
	Details of current commitments: Available as per Requirement	
Source	Indicate source of the equipment Owned <input type="checkbox"/> Rented <input checked="" type="checkbox"/> Leased <input checked="" type="checkbox"/> Specially manufactured	
Remarks	<input type="checkbox"/> Catalogues, drawings and/or other similar materials are attached. <input checked="" type="checkbox"/> Catalogues, drawings and/or other similar materials are not attached.	
Owner	Name of owner: Anand Prakash	
	Address of owner: 7 Main stand Near Park VPO Mubarkur Dabas, New Delhi	
	Telephone: +91-7011995937	Contact name and title: Anand (Owner)
	Fax: NA	Telex: NA
Agreements	Details of rental/ lease/ manufacture agreements specific to the project	
	These details Will be provided Later	



STRABAG Infrastructure & Safety Solutions GmbH  
Ignaz-Koeck-Str 19  
1210 Wien/Osterreich  
www.strabag-iss.com

Sitz: Wien, Handelsgericht Wien, FN 79686p UID Nr.: ATU14764502

Gedruckt auf 100 % Recyclingpapier



Tel: +43 1 90199-0  
Fax: +43 1 90199-19  
iss-office@strabag.com

Raffineriebancasbank Oberoster AG  
IBAN: AT91 3400 0000 0014 1317  
BIC/SWIFT: RZOOAT2LXXX



2193

Technical Proposal

Mobilization Schedule

Form MAN





004247

EFKON INDIA PVT. LTD., 1115, 11th Floor, Rupa Solitaire, Building No. A-1 Sector 1, Millennium Business Park, Navi Mumbai, Mahape, Thane - 400710

### Form MAN: Manufacturer's Authorization

Date: 08/12/2021

IFB No.: MMRDA/ENG1/0002561

Bidder's Name: JV of STRABAG Infrastructure & Safety Solutions GmbH and STRABAG AG  
Part of the Works: Total Solution of Toll Management System & Total Solution of Highway Traffic Management System

To: Mumbai Metropolitan Region Development Authority ("the Employer")

WHEREAS the Bidder is willing to submit to the Employer a Bid for Package-4 of the Mumbai Trans Harbor Link Project involving part of the above-mentioned Solution of Toll Management System & Highway Traffic Management System we are supplying as an ITS Contractor & Software Developer, and

WHEREAS the Employer is willing to secure authorization of the manufacturer of the Solution of Toll Management System & Highway Traffic Management System.

NOW THEREFORE we EFKON India Private Limited, as an official ITS Contractor & Software Developer of Toll Management System & Highway Traffic Management System, having office at 1115, Rupa Solitaire, Millenium Business Park, MIDC Industrial Area, Sector 1, Mahape, Navi Mumbai, Maharashtra: 400710, do hereby authorize JV of STRABAG Infrastructure & Safety Solutions GmbH and STRABAG AG to submit a Bid, the purpose of which is to design, supply, install, complete and make good any defects in the Works including Toll Management System & Highway Traffic Management System to be supplied by us, and to subsequently negotiate and sign the Contract.

Yours sincerely,

For EFKON India Private Limited

Name:

Designation:



Gurpreet Singh Basra  
Authorized Signatory



Tarun Sharma  
Authorized Signatory

Duly authorized to sign the bid for and on behalf of: EFKON India Private Limited.

Registered Office:  
EFKON INDIA PVT. LTD.  
1115, 11th Floor, Rupa Solitaire, Building No. A-1,  
Sector 1, Millennium Business Park, Navi Mumbai  
Mahape, Thane - 400710  
CIN NO. - U72900MH2001PTC132670

Tel. : +91 22 42949494  
Fax : +91 22 42949333  
Web. <http://www.efkonindia.com>

2195





004248

EFKON INDIA PVT. LTD., 1115, 11th Floor, Rupa Solitaire, Building No. A-1 Sector 1, Millennium Business Park, Navi Mumbai, Mahape, Thane - 400710

### Declaration for country of origin

Date: 01/12/2021

IFB No.: MMRDA/ENG1/0002561

Bidder's Name: JV of STRABAG Infrastructure & Safety Solutions GmbH and STRABAG AG  
Part of the Works: Total Solution of Toll Management System & Total Solution of Highway Traffic Management System

To: Mumbai Metropolitan Region Development Authority ("the Employer")

Dear Sir,

We, Efkon India Private Limited, in the capacity of Subcontractor for, Schedule No. 5: Toll Management System & Schedule No. 6: Advanced Traffic Management System, do hereby declare that the country of origin for proposed system is India.

Yours sincerely,

For EFKON India Private Limited

Name:

Designation:



Gurpreet Singh Basra  
Authorized Signatory



Tarun Sharma  
Authorized Signatory

Duly authorized to sign the bid for and on behalf of: EFKON India Private Limited



Registered Office:  
EFKON INDIA PVT. LTD.  
1115, 11th Floor, Rupa Solitaire, Building No. A-1,  
Sector 1, Millennium Business Park, Navi Mumbai  
Mahape, Thane - 400710  
CIN NO. : - U72900MH2001PTC132670

Tel. : +91 22 42949494  
Fax : +91 22 42949333  
Web : <http://www.efkonindia.com>

2196





## Form MAN: Manufacturer's Authorization

Date: [3<sup>rd</sup> December 2021]

IFB No.: MMRDA/ENG1/0002561

Bidder's Name: [JV of STRABAG Infrastructure & Safety Solutions GmbH and STRABAG AG]

Plant or Material or part of the Works: [VRF Outdoor and Indoor Units]

To: Mumbai Metropolitan Region Development Authority ("the Employer")

WHEREAS the Bidder is willing to submit to the Employer a Bid for Package-4 of the Mumbai Trans Harbor Link Project involving part of the above-mentioned [VRF Outdoor and Indoor Units] we Carrier Airconditioning and Refrigeration manufacture and  
WHEREAS the Employer is willing to secure authorization of the manufacturer of the [Ventilation Axial, Centrifugal, Inline, Propeller and Jet Fans].

NOW THEREFORE we Carrier Airconditioning and Refrigeration Limited, as an official manufacturer of [VRF Outdoor and Indoor Units], having factory at Carrier Airconditioning and Refrigeration Limited, Narsingpur, Gurgaon do hereby authorize JV of STRABAG Infrastructure & Safety Solutions GmbH and STRABAG AG to submit a Bid, the purpose of which is to design, supply, install, complete and make good any defects in the Works including [VRF Outdoor and Indoor Units] to be supplied by us, and to subsequently negotiate and sign the Contract.

Name: Nayan Das

In the capacity of Sales Manager



Duly authorized to sign for and on behalf of: Carrier Airconditioning and Refrigeration Limited



Carrier Airconditioning & Refrigeration Limited

Branch Off. : Unit No 4, Level 2, 15 LBS, Phoenix Market City, Kamani, LBS Road, Kurla (W), Mumbai-400070  
Tel. : +91-22-61700700, Fax : +91-22-61700800

Regd. Off. : Narsingpur, Kherki Daula Post, Delhi-Jaipur Highway, Gurgaon-122004, Haryana  
Tel. : +91-121-4825500, Fax : +91-124-2372230

CIN : U74199HR1902FLC036101, www.carrierindia.com, customersupport.india@carrier.aic.com







**CRYPTZO ENGINEERING PVT. LTD.**

CIN No.: U29253MH2015PTC265281

## Form MAN: Manufacturer's Authorization

Date: 06/12/2021

IFB No.: MMRDA/ENG1/0002561

Bidder's Name: [Everest Kanto Cylinder Ltd.]

Plant or Material or part of the Works: [Clean Agent based Fire Suppression system]

To: Mumbai Metropolitan Region Development Authority ("the Employer")

WHEREAS the Bidder is willing to submit to the Employer a Bid for Package-4 of the Mumbai Trans Harbor Link Project involving part of the above-mentioned Clean Agent Fire Suppression system We M/S. Cryptzo Engineering Pvt Ltd WHEREAS the Employer is willing to secure authorization of the manufacturer of the Clean Agent Fire Suppression system.

NOW THEREFORE we M/S. Cryptzo Engineering Pvt Ltd as an official manufacturer of Clean Agent based Fire Suppression system having factories at Plot no. A-158 & 159, Vile Bhagad MIDC Industrial Area, Tal. Mangaon, Dist. Raigad, Pin – 402308, India We hereby authorize M/S. Everest Kanto Cylinder Ltd to submit a Bid, the purpose of which is to design, supply, install, complete and make good any defects in the Works including Clean Agent Fire Suppression system to be "manufactured" by us, and to subsequently negotiate and sign the Contract.

Name-Sachin Darne

In the capacity of DIRECTOR



Duly authorized to sign for and on behalf of: CRYPTZO ENGINEERING PVT. LTD.



MX Systems International Pvt. Ltd.

**MINIMAX**

A member of Minimax Viking Group

**Form MAN: Manufacturer's Authorization**

Date: 06/12/2021

IFB No.: MMRDA/ENG1/0002561

Bidder's Name: [JV of STRABAG Infrastructure & Safety Solutions GmbH and STRABAG AG]  
Plant or Material or part of the Works: [Gas suppression system]**To: Mumbai Metropolitan Region Development Authority ("the Employer")**

WHEREAS the Bidder is willing to submit to the Employer a Bid for Package-4 of the Mumbai Trans Harbor Link Project involving part of the above-mentioned **Gas Suppression System** We **MX Systems International Pvt. Ltd.** WHEREAS the Employer is willing to secure authorization of the Manufacturer/Supplier of the **Gas Suppression System**.

NOW THEREFORE we **MX Systems International Pvt. Ltd** as an official manufacturer of Gas Suppression System having factories at **C/o. Engineering & Fabrication works, MIDC-Plot no.M-88/1, Additional Murbad Industrial Area, Near MIDC Fire Station, Taluka- Murbad, Dist.-Thane. Maharashtra-410206**, We hereby authorize **JV of STRABAG Infrastructure & Safety Solutions GmbH and STRABAG AG** to submit a Bid, the purpose of which is to design, supply, install, complete and make good any defects in the Works including **Gas Suppression System** to be "manufactured/supplied" by us and to subsequently negotiate and sign the Contract.

  
Name: [ARUN BHANOT]
In the capacity of **GENERAL MANAGER-NORTH**Duly authorized to sign for and on behalf of: **MX SYSTEMS INTERNATIONAL PVT. LTD.**

**Regd. & Head Office:**  
**MX Systems International Pvt. Ltd.**  
 3rd floor, T/7,  
 Pinnacle Business Park,  
 Mahakali Caves Road, Andheri (E),  
 Mumbai - 400 093, India.  
 Phone : + 91-22-6154 1000  
 Fax : + 91-22-2839 0681  
 Email : info@minimaxindia.co.in  
 Email : RjhwaniG@minimaxindia.co.in  
 Website : http:// www.minimax-viking.com  
 CIN: U74210MH2005FTC155727



**Delhi (NCR) Office:**  
**MX Systems International Pvt. Ltd.**  
 425, Sector 18,  
 Okhla Industrial Area, Noida  
 U.P. - 201 301, India.  
 Phone : + 91-120-4217829  
 Fax : + 91-120-4217832  
 Email : info@minimaxindia.co.in  
 Email : BhanotA@minimaxindia.co.in  
 Website : http:// www.minimax-viking.com

**Kolkata Office:**  
**MX Systems International Pvt. Ltd.**  
 761/1, Jessore Road,  
 Green Park, Block - A,  
 Ground Floor, (Western Side)  
 Kolkata - 700055.





**Manufacturer's Authorization Form**

Date: 06/12/2021

IFB No.: **MMRDA/ENG1/0002561**

Bidder's Name: [JV of STRABAG Infrastructure & Safety Solutions GmbH and STRABAG AG]

Plant or Material or part of the Works: 11 kV Compact Sub Station (CSS)

To: Mumbai Metropolitan Region Development Authority ("the Employer")

WHEREAS the Bidder is willing to submit to the Employer a Bid for Package-4 of the Mumbai Trans Harbor Link Project involving part of the above mentioned 11 kV Compact Sub Station (CSS) we ABB India Limited, and WHEREAS the Employer is willing to secure authorization of the manufacturer of the 11 kV Compact Sub Station (CSS) WHEREAS the Employer is willing to secure authorization of the manufacturer of the 11 kV Compact Sub Station (CSS).

NOW THEREFORE we ABB India Limited, as an official manufacturer of 11 kV Compact Sub Station (CSS), having factory at Satpur, Nashik, Maharashtra, do hereby authorize JV of STRABAG Infrastructure & Safety Solutions GmbH and STRABAG AG to submit a Bid, the purpose of which is to design, supply, install, complete and make good any defects in the Works including 11 kV Compact Sub Station (CSS) to be manufactured by us, and to subsequently sign the Contract.

For and on behalf of **ABB India Limited**

Yours Faithfully,

Name: Mr. Anil Gupta

Title : Assistant Vice President

Duly authorized to sign this Authorization on behalf of **ABB India Limited**

Dated on 06<sup>th</sup> Dec 2021



**ABB India Limited**  
(Formerly known as ABB Limited)  
Registered Office & Corporate Office  
Plot No. 5 & 6, 2<sup>nd</sup> Stage  
Peenya Industrial Area IV, Peenya  
Bengaluru - 560 058 Karnataka

CIN: U72200KA2011PTC031199  
GST: 29AAACA3831B100



**Regional Office-North**  
14, Mathura Road  
Faridabad, - 121003  
Haryana, INDIA

Phone: +91 129 2275592  
+91 129 2279627  
Fax: +91 129 2275019  
+91 129 2279692  
[www.abb.com/in](http://www.abb.com/in)



**2200**



**SUPERNOVA**  
ENGINEERS LTD.

Building Powerful Relationships

(An ISO 9001 & ISO 14001 Certified Company)

Office: 204/205, Agarwal Arcade -VI, Near Jainagar Railway Station, Sector-I, Nerul, Navi Mumbai - Pune road,  
Navi Mumbai- 400 706

[www.supernovagenet.com](http://www.supernovagenet.com)

## Form MAN: Manufacturer's Authorization

Date: 10.12.2021

IFB No.: MMRDA/ENG1/0002561

Bidder's Name: [JV of STRABAG Infrastructure & Safety Solutions GmbH and STRABAG AG]

Plant or Material or part of the Work:- DG set material

To: Mumbai Metropolitan Region Development Authority ("the Employer")

WHEREAS the Bidder is willing to submit to the Employer a Bid for Package-4 of the Mumbai Trans Harbor Link Project involving part of the above-mentioned [insert "Plant" or "Material" as appropriate] we Supernova Engineers Ltd, and WHEREAS the Employer is willing to secure authorization of the manufacturer of the [insert "Plant" or "Material" as appropriate].

NOW THEREFORE we **Supernova Engineers Ltd** having our registered office at **F-2, B Wing, First Floor, Opp. Gujarat High Court, S.G. Road, Ahmedabad-380060**, manufacturer of DIESEL GENERATOR SETS do hereby authorize **JV of STRABAG Infrastructure & Safety Solutions GmbH and STRABAG AG** to submit a Bid, the purpose of which is to design, supply, install, complete and make good any defects in the Works including [insert name and/or brief description of the Plant or Material] to be [insert "manufactured" or "supplied" / by us, and to subsequently negotiate and sign the Contract.

For <Supernova Engineers Ltd.>



Authorized Signature [In full and initials]:

Name and Title of Signatory: Mr. Sachin Savla (GM- Sales & Marketing)

Name of Firm: Supernova Engineers Ltd.



Registered Office:

F-2, B Wing, First Floor, Shapath Hexa, Opp. Gujarat High Court, Nr Sola Bridge, Sarkhej - Gandhinagar Highway, Ahmedabad

380 060



2201



aspire. ascertain. accomplish.

## Form MAN: Manufacturer's Authorization

Date: 01.12.2021

IFB No.: MMRDA/ENG1/0002561

Bidder's Name Novateur Electrical &amp; Digital Systems Pvt. Ltd. (ADLEC)

Plant of the Works: Rohad By Pass, Behind IUP Jindal, Decora Station Road, Rohad, Jhajjar, Haryana, 124501

To,  
Mumbai Metropolitan Region Development Authority

WHEREAS the Bidder is willing to submit to the Employer a Bid for Package-4 of the Mumbai Trans Harbor Link Project involving part of the above-mentioned Plant, we manufacturer of HT Panels, LT Panels and BBT, and WHEREAS the Employer is willing to secure authorization of the manufacturer of the HT Panels, LT Panels and BBT.

NOW THEREFORE we Novateur Electrical & Digital Systems Pvt. Ltd. as an official manufacturer of HT Panels, LT Panels and BBT, having factory at Rohad By Pass, Behind IUP Jindal, Decora Station Road, Rohad, Jhajjar, Haryana, 124501, do hereby authorize JV of STRABAG Infrastructure & Safety Solutions GmbH and STRABAG AG to submit a Bid, the purpose of which is to design, supply, install, complete and make good any defects in the Works including Novateur Electrical & Digital Systems Pvt. Ltd. (Rohad Haryana) to be manufactured by us, and to subsequently negotiate and sign the Contract.

Thanking You  
For and on behalf of M/s. Novateur Electrical & Digital Systems Pvt. Ltd. (ADLEC)



Name: Pinky Singh  
(Manager - Estimation)



Novateur Electrical & Digital Systems Pvt. Ltd.  
CIN: U31909MH2010PTC204487  
Registered Office: 61/62, 6th Floor, Kalpataru Square,  
Kondivita Road, Off Andheri-Kurla Road,  
Andheri (East) Mumbai- 400059, Maharashtra, India.  
Ph: 022-30416300 Fax: 022-30416201  
Email: adlec@adlecpower.com

Rohad Works:  
Delhi Rohak Road, Decora Station Road,  
Behind IUP Jindal, Rohad,  
Distt-Jhajjar-124501 (Haryana)  
Ph: 8607888111



# KEI

**KEI Industries Limited**

Regd. Office & works: D-90, Okhla Industrial Area, Phase - I New Delhi - 110020 CIN: L74899DL1992PLC051527  
Tel: 011-26818840/8642/0242, Fax: 26817225, 26811959. Email: delhi@kei-ind.com Website: www.kei-ind.com

## Manufacturer's Authorization FORM

Date: 26.11.2021

IFB No.: MMRDA/ENG1/0002561

Bidder's Name: [JV of STRABAG Infrastructure & Safety Solutions GmbH and STRABAG AG]

To: Mumbai Metropolitan Region Development Authority ("the Employer")

WHEREAS the Bidder is willing to submit to the Employer a Bid for Package-4 of the Mumbai Trans Harbor Link Project involving part of the above-mentioned i.e. Cables and Wires we **KEI INDUSTRIES LTD** " Who are official manufacturer of Cables and Wires having factories at following address:

- SP-919/920/922, RICCO Industrial Area, Phase-III, Bhiwadi, Distt. Alwar, Rajasthan
- 99/2/7, Madhuban Industrial Estate, Rakholi, Silvassa, Union Territory of Dadar and Nagar Haveli,
- A-280/281/282/283/284, RIICO Industrial Area Chopanki Industrial Area, Bhiwadi, Distt. Alwar, Rajasthan,
- SP-2-874, RIICO Industrial Area, Pathredi, Distt. Alwar, Rajasthan 301019.

do hereby authorize **JV of STRABAG Infrastructure & Safety Solutions GmbH and STRABAG AG** to submit a bid the purpose of which is to provide the following Goods, manufactured by us (i.e Cables and Wires) and to subsequently negotiate and sign the Contract.

We hereby extend our full warranty for a period of 12 months from the date of commissioning or 18 months from the date of dispatch whichever is earlier with respect to the goods offered by us.

For KEI Industries Ltd.



Jyoti Malhotra  
Manager Marketing

Duly authorized to sign the authorization for and on behalf of **KEI INDUSTRIES LTD** on dated 26.11.2021



Works-I : Bhiwadi : SP-919/920/922, RIICO Industrial Area, Phase-III, Bhiwadi, Dist. Alwar-301019 (Raj) Tel : 01493-220106/1731 Fax : 01493-22132  
Works-II : Bhiwadi : A-280-284, RIICO Industrial Area, (Chaupanki), Dist. Alwar-301019 (Rajasthan) Tel : 01493-260202/05 Fax : 01493-260203  
Works-III : Silvassa : 99/2/7, Madhuban Industrial Estate, Rakholi, Silvassa UT of D & N.H-396240. Tel/Fax : 0091-350-2644404, 2639444, 2645896  
Marketing Office: 811/102, Vashi Ship, Vashi Enclave, Andheri Pump House, Andheri East, Mumbai - 400093. Tel: 022-28239673, Fax: 28258777

Selected  
**BUSINESS**  
**Superbrand**  
Industry Valued

**RMCON**

STEEL CONDUITS, CABLE TRAYS &amp; RACEWAYS, RACEWAYS



An ISO 9001 : 2015 Company

# RMG Steels Pvt. Ltd.

- B-91 Sector-80, Noida-201305, G.B. Nagar (U.P.)
- 0120-6252588 / 89
- rmgsteeelspvtltd@gmail.com | info@rmcon.in
- www.rmcon.in
- U28112DL2012PTC242522 / GSTIN No. 09AAGCR0665K1Z1

## FormMAN:Manufacturer'sAuthorization

Date 04.12.2021

IFBNo MMRDA/ENG1/0002561

Bidder'sName [JV of STRABAG Infrastructure &amp; Safety Solutions GmbH and STRABAG AG]

Plant or Material or part of the Works [insert 'Plant' or 'Material as appropriate]

To: Mumbai Metropolitan Region Development Authority (the Employer)

WHEREAS the Bidder is willing to submit to the Employer a Bid for Package-4 of the Mumbai Trans Harbor Link Project involving part of the above-mentioned material we *RMG Steels Pvt Ltd* and whereas the Employer is willing to secure authorization of the manufacturer of the material

NOW THEREFORE we *RMG Steels Pvt Ltd* as an official manufacturer of Cable Tray Raceways & Accessories having factory at B-91, Sector - 80 Noida - 201305 do hereby authorize *JV of STRABAG Infrastructure & Safety Solutions GmbH and STRABAG AG* to submit a Bid, the purpose of which is to design, supply, install, complete and make good any defects in the Works including *RMCON make Cable Trays Raceway* to be supplied by us, and to subsequently negotiate and sign the Contract

Name Tanya Singh

Duly authorized to sign for and on behalf of RMG Steels Pvt Ltd



- ERW Rigid Steel Conduits
- Rigid Steel Conduit Fitting
- Cable Trays, Raceways & Fitting
- Modular Boxes

Head Office : 1st Floor, N-10, Greater Kailash - 1, New Delhi - 110048

14<sup>th</sup> March 2018

Ref: FTME/527/JPD

To Whom it may concerns,

**EKC International FZE and Everest Kanto Cylinder Ltd**

This letter confirms that EKC International FZE located in Dubai, United Arab Emirates and Everest Kanto Cylinder Ltd are authorised distributors of Firetrace USA LLC for India and its sub-continent

They have been trained by Firetrace to undertake design, supply, installation and commissioning of Firetrace systems in accordance with our design installation operation manuals and various international approvals.

I trust that letter offers some clarification for you, if you any additional information please do not hesitate to contact me directly

Yours Sincerely



**Jim Dickinson**  
 International Sales Director  
 Europe, Middle East, Africa & Asia.

Tel : +971567599490

Email: [jdickinson@firetrace.com](mailto:jdickinson@firetrace.com)

Skype: jim.dickinson1

[www.firetrace.com](http://www.firetrace.com)

**WORLD HEADQUARTERS** - Firetrace International, LLC,  
 8435 N. 90th St Suite 2, Scottsdale, AZ 85258.  
 Tel: +1 480 607 1218 Fax: +1 480 315 1316

**EMEA OFFICE** - Firetrace International Ltd, Unit 11, IO Centre,  
 Saltbrook Road, Salfords, Surrey, RH1 5DY, United Kingdom.  
 Tel: +44 (0) 1293 780 390 Fax: +44 (0) 1293 780 399

**FIRETRACE USA LLC (MIDDLE EAST BRANCH)** - Office  
 2117, Building 7WB, Dubai Airport Freezone (DAFZA),  
 Dubai, United Arab Emirates. Tel: +971 56 7599490